

veke

Item name: Kaunas tuoli tammi/ musta PU
Kaunas tuoli espresso/ musta PU
SKU: 6466582 / 6474464
EAN code: 6438499066582 / 6474464
Packing size: 1050x730x130mm
Gross weight: 13.7kg

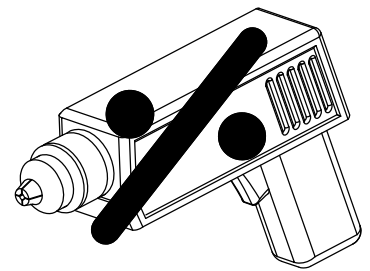
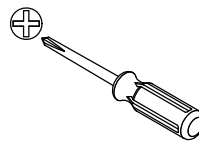
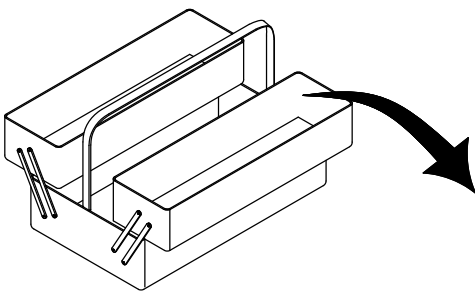
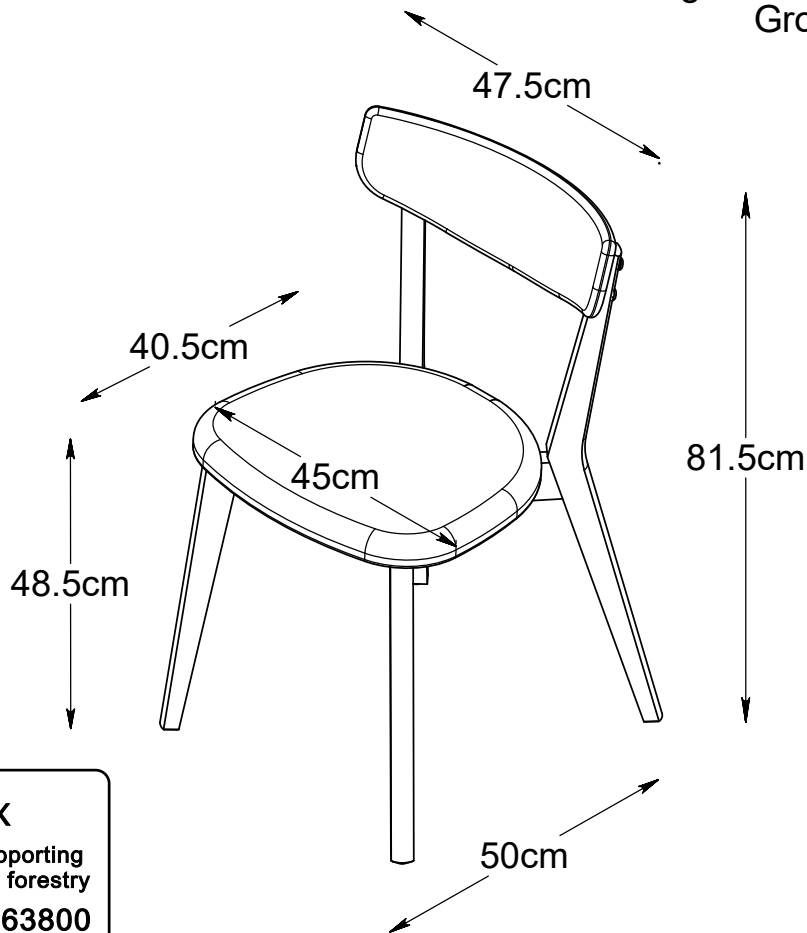

NOTICE - These instructions must be saved for future use - Instructions must be followed

WICHTIG - FÜR SPÄTERE VERWENDUNG AUFBEWAHREN - SORGFÄLTIG LESEN

IMPORTANTE, conservar estas instrucciones para futuro uso. Siga estas instrucciones atentamente

AVIS - Ces instructions doivent être sauvegardées Pour utilisation future - Les instructions doivent être suivies

VIGTIGT - Samlevejledningen skal opbevares i arkiv til senere brug - Skal gennemlæses nøje

HUOMAUTUS - Nämä ohjeet on säilytettävä myöhempää käyttöä varten - Ohjeita on noudatettava

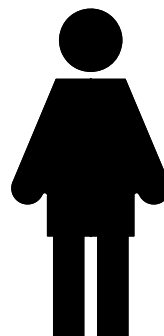

CHECK LIST
 TEILCHECKLISTE
 LISTADO DE CONTROL
 LISTE DE CONTROLE
 TJEKLISTE

Réf./No.	Réf./Art.	Qty./Stck./Quantité	Size / Maß / Dimension (mm)	Qty./Stck./Quantité	✓
1	32322602	1	765x664x30		
2	32322702	1	765x664x30		
3	32322802	1	460x155x18		
4	32322902	2	90x50x40		
5	32323002	2	105x50x40		
6	323233	1	450x405x40		

26882203



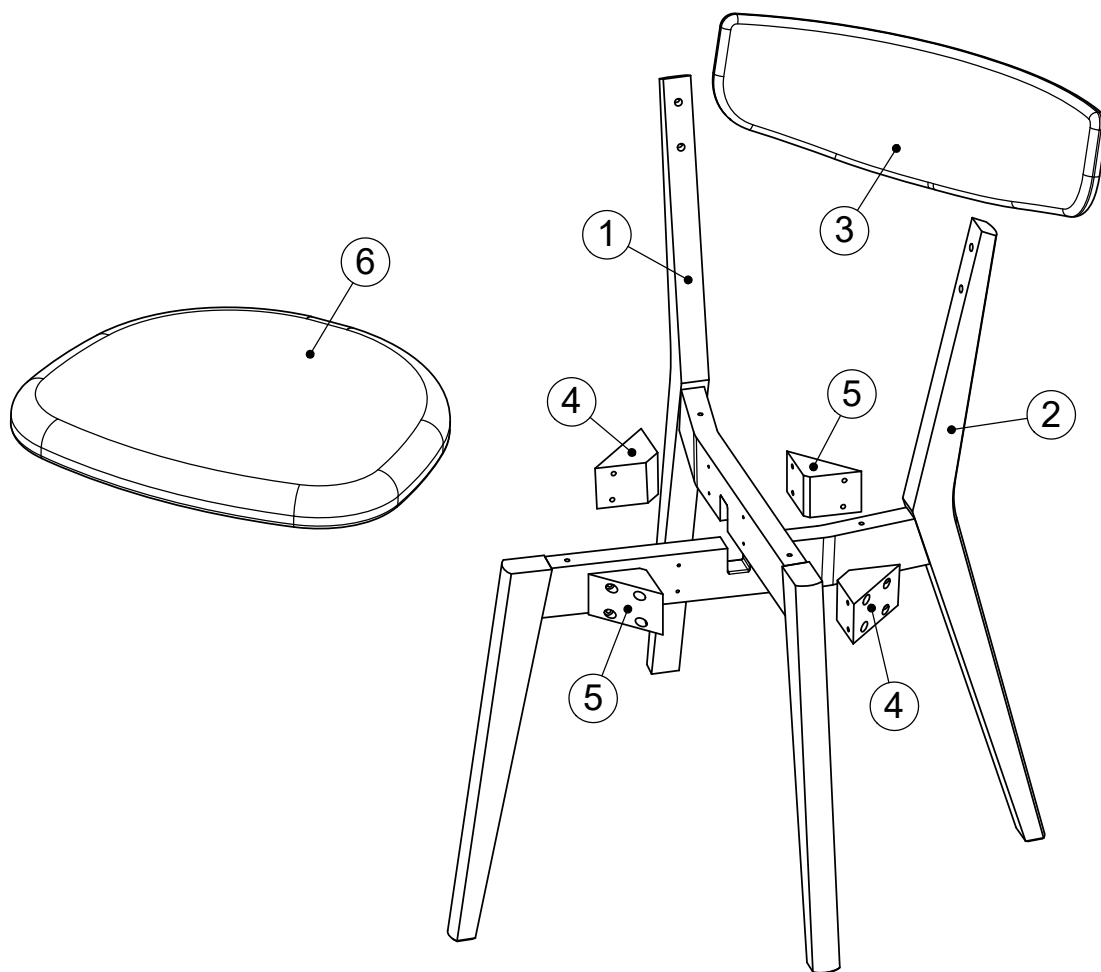

Réf./No.	Réf./Art.	Qty./Stck./Quantité	Size / Maß / Dimension (mm)	Qty./Stck./Quantité	✓
1	32322602	1	765x664x30		
2	323227318	1	765x664x30		
3	323228318	1	460x155x18		
4	323229318	2	90x50x40		
5	323230318	2	105x50x40		
6	32323303	1	450x405x40		

26882185

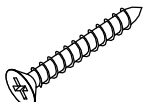

TEILCHECKLISTE - LISTE DE CONTROLE - LISTADO DE CONTROL- TJEKLISTE - CHECK LIST

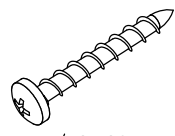
Réf./No.	Réf./Art.	Qty./Stck./Quantité	✓
A	32323202	4	
B	32323202	16	
C	32323202	1	
D	32323202	4	
E	32323202	4	
F	32323202	4	

4 - A	16 - B	1 - C	4 - D	4 - E	4 - F
 M6x20mm	 Ø4x30mm	 4mm	 Ø16x12mm	 Ø4x40mm	 Ø20x3mm

Dear Customer.
Below you have the opportunity to measure the
Enclosed Hardware.

Geehrter Kunde.
Hier haben Sie die Möglichkeit die mitgelieferten
Schrauben nachzumessen.

Estimado cliente.
aquí podrá medir la tornillería adjunta.

Cher Client.
La règle ci jointe vous permet de mesurer la visserie.

Kære kunde.
Her har De muligheden for at måle medsendte beslag.

Hyvä asiakas.
Alta voit mitata pakkauksessa olevat laitteet.

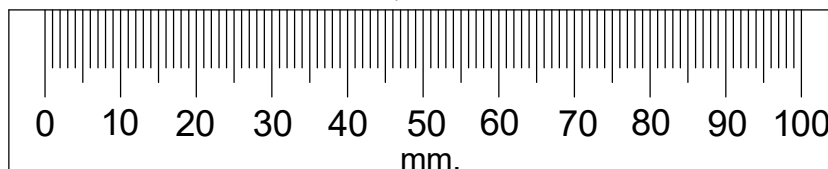

1

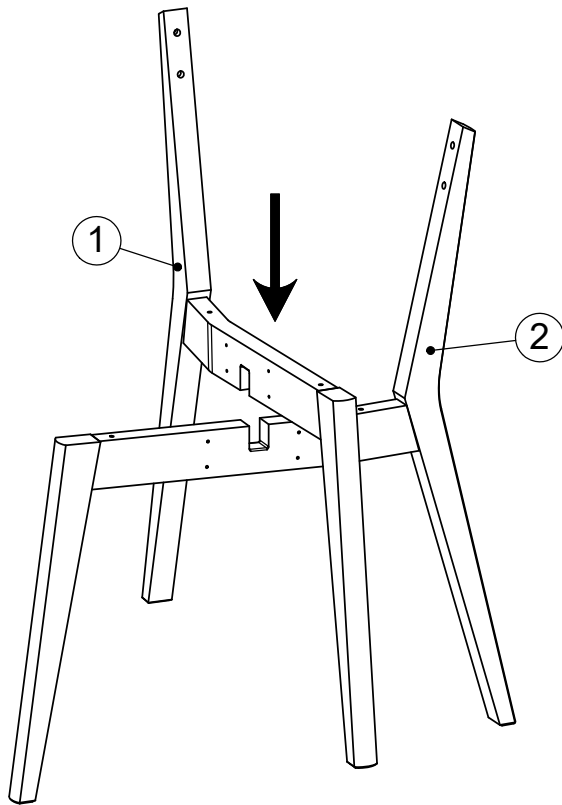

2 4 - A 1 - C

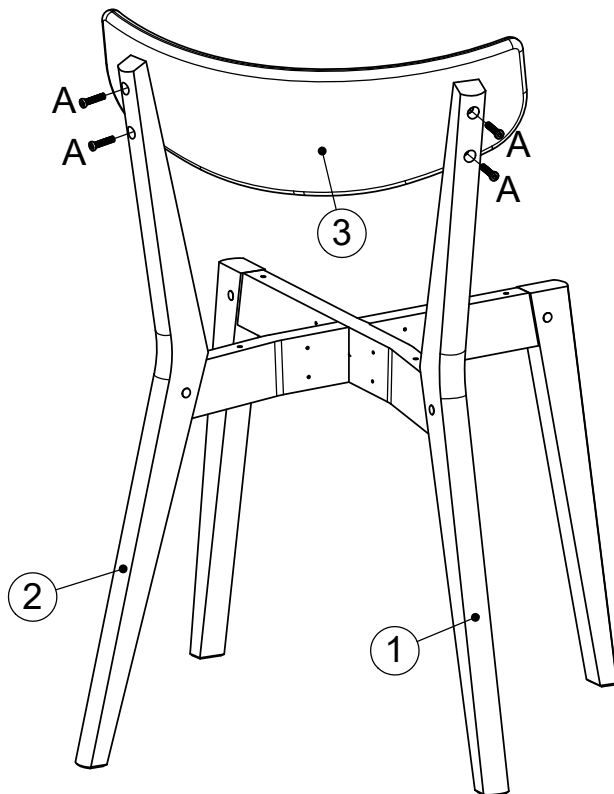

3 16 - B  

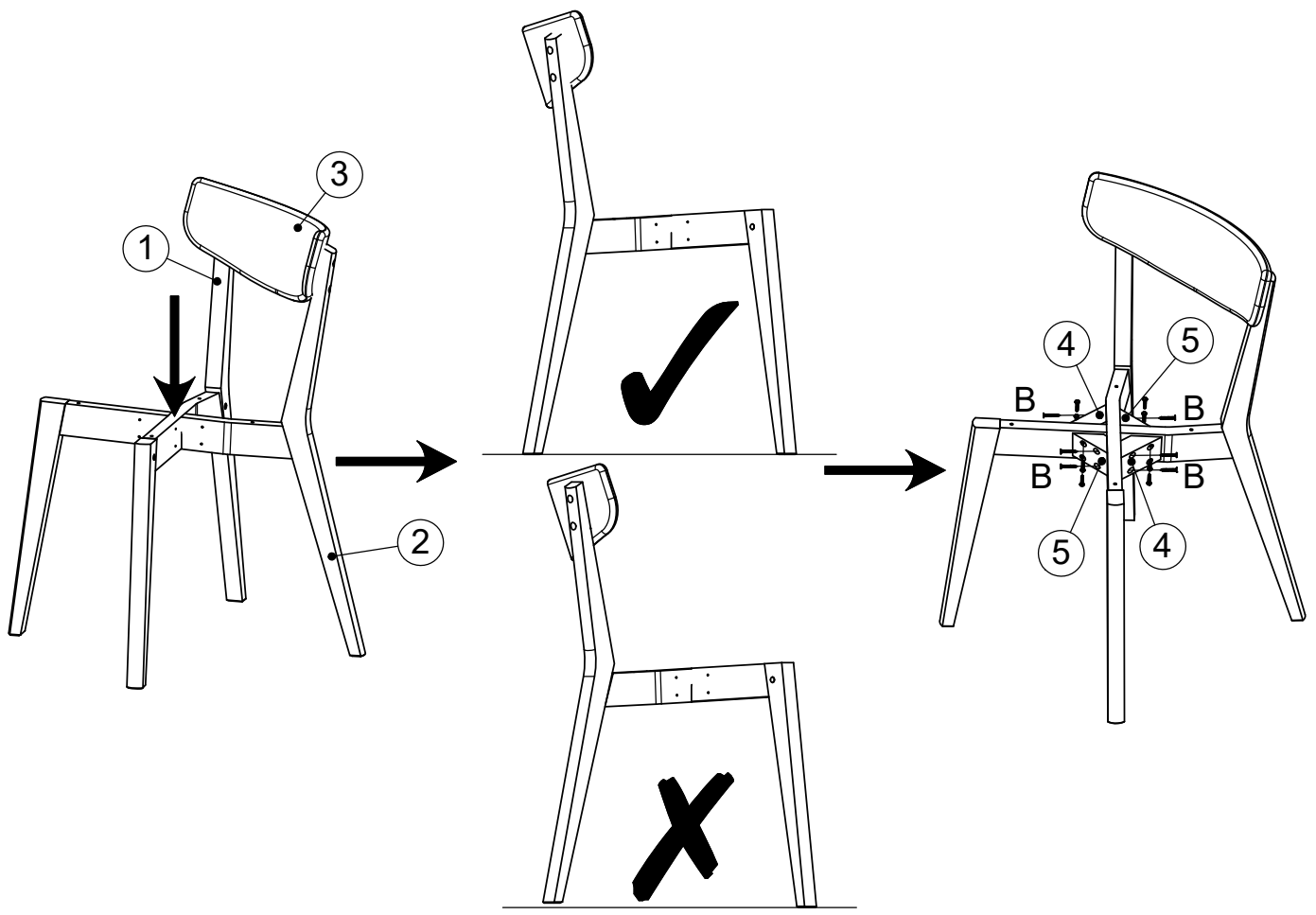

4 4 - D 1 - C  

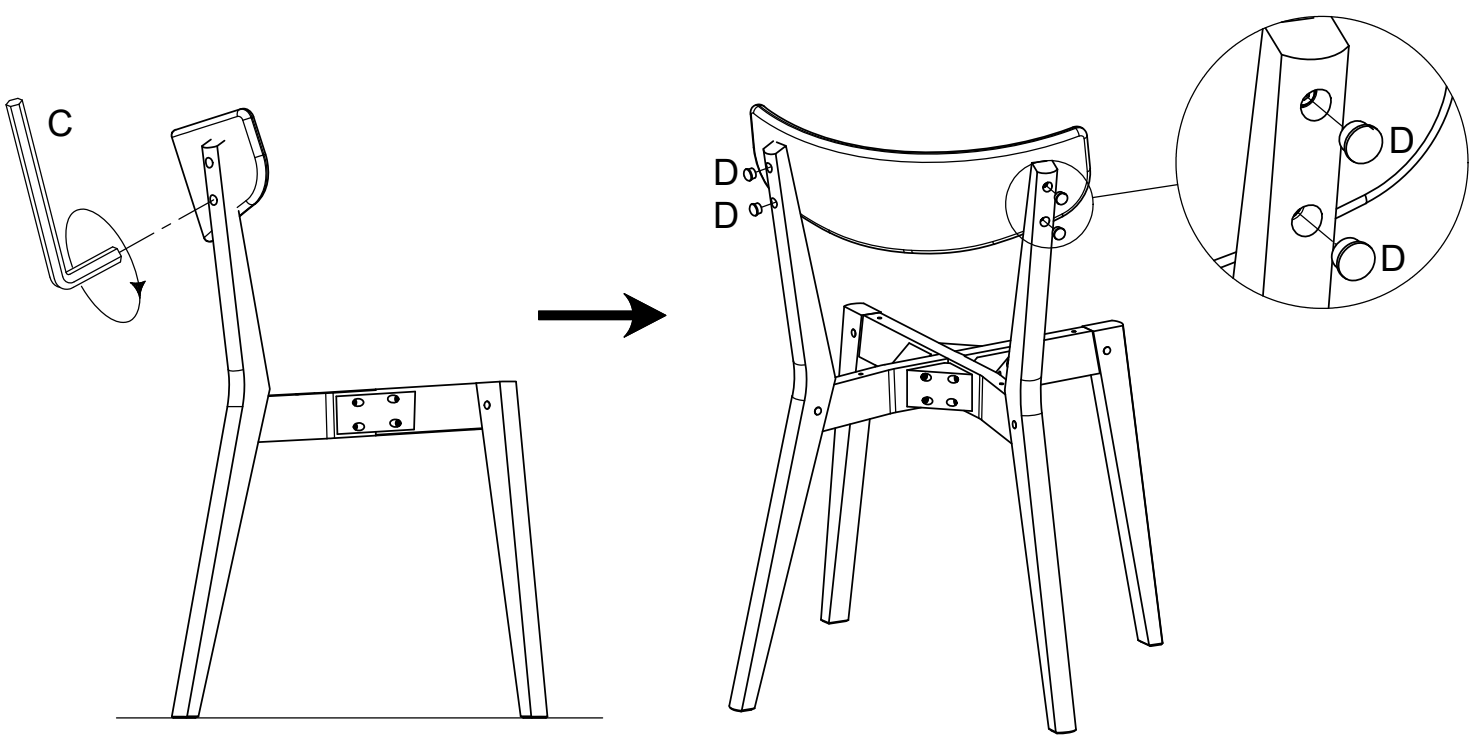

5 4 - E 4 - F 

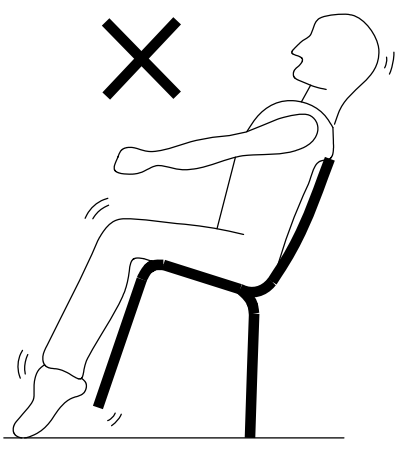
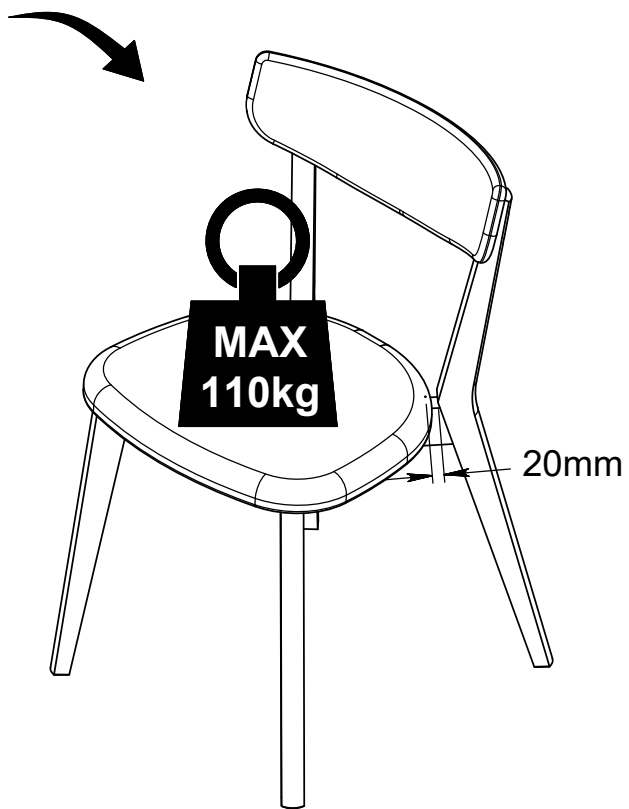
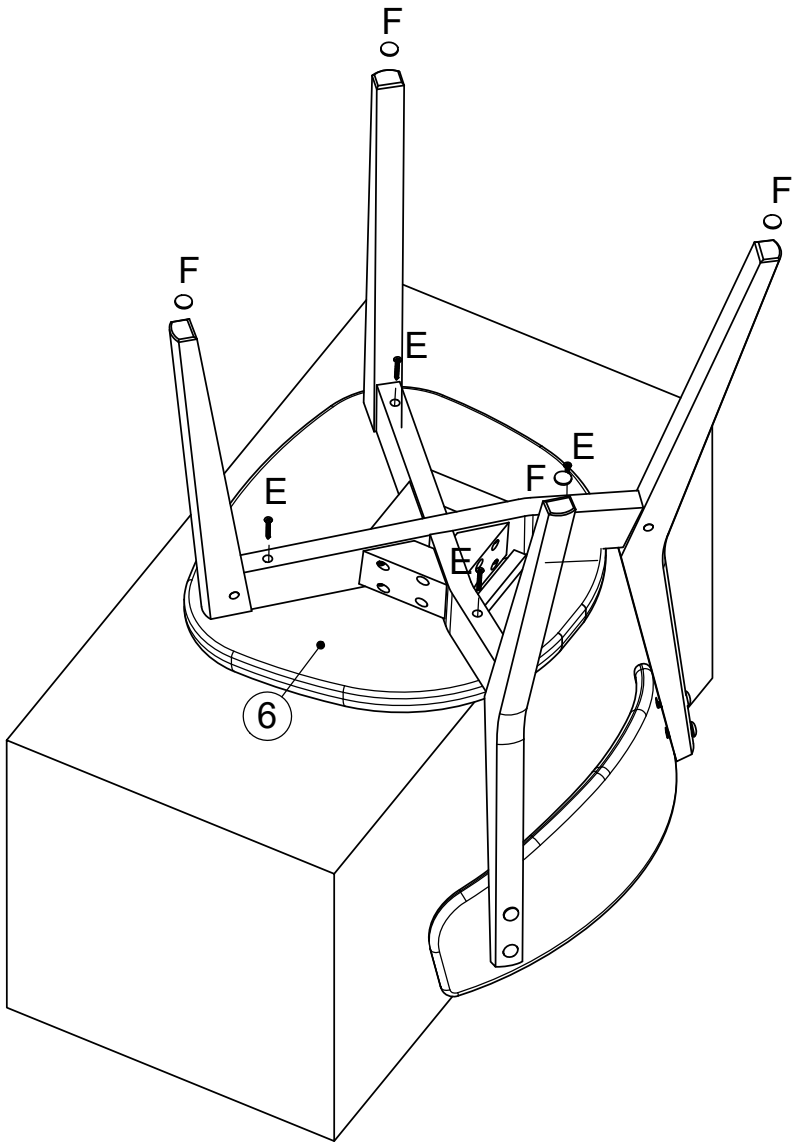



UK:

Always ensure the feet / felt pads provided with this product are suitable for your flooring.
Periodically check the position of any foot caps/felt pads used to ensure your floors are protected.

DE:

Wichtig : Bitte stellen Sie immer sicher , dass die mit diesem Produkt gelieferten FüÙe für Ihren Bodenbelag geeignet sind !
Bitte überprüfen Sie regelmäßig die Position der verwendeten Fußkappen oder Filzgleiter um sicherzustellen dass Ihre Böden geschützt sind !

ES:

Asegúrese siempre que los tapones de las patas de este producto son compatibles con su suelo.
Periódicamente revise que sus tapones y sus almohadillas de fieltro están correctamente colocadas para asegurar que su suelo esté protegido.

FR:

Assurez-vous toujours que les pieds/ patins fournis avec le produit sont compatibles avec le sol.
Contrôlez régulièrement la position des patins utilisés pour que vos sols soient protégés.

DK:

Sørg altid for at beskyttelse fødder / filt puderne der følger med dette produkt, passer til Deres gulv.
Kontroller regelmæssigt placeringen at evt. beskyttelse fødder / filt puder er korrekt placeret for bedste beskyttelse af gulvene.

FI:

Varmista aina, että tämän tuotteen mukana toimitetut jalat tai huopatassut soveltuvat käytössä olevalle lattiapinnalle.
Tarkista säännöllisesti jalkojen tai huopatassujen asento ja kunto varmistaaksesi, että lattia pysyy suojattuna.



UK:

It is important that any product which is assembled using any kind of screw is re-tightened 2 weeks after assembly,
and once every 3 months - in order to assure stability through-out the lifespan of the product.

DE:

Es ist wichtig, bei jedem mit Schrauben montierten Produkt diese 2 Wochen nach dem Zusammenbau sowie einmal alle 3 Monate wieder anzuziehen, um die Stabilität des Produkts über die gesamte Lebensdauer hinweg zu gewährleisten.

ES:

En el caso de los productos ensamblados, es importante volver a apretar los tornillos 2 semanas después del montaje y después cada 3 meses, para así preservar la estabilidad durante toda la vida útil del producto.

FR:

Il est important que tout produit monté à l'aide de vis soit resserré 2 semaines après son montage,
puis tous les 3 mois, afin de garantir sa stabilité durant tout son cycle de vie.

DK: VIGTIGT!

Det er vigtigt, at alle produkter, der samles med alle former for skruer, efterspændes to uger efter samling samt hver tredje måned for at sikre, at produktet er stabilt i hele dets levetid.

FI:

On tärkeää, että kaikki ruuveilla kootut tuotteet kiristetään uudelleen kahden viikon kuluttua kokoamisesta ja kolmen kuukauden välein tuotteen vakauden varmistamiseksi koko käyttöiän ajan.