

MOND

14310762, 16520668
LKZ 42416 / 75033

09

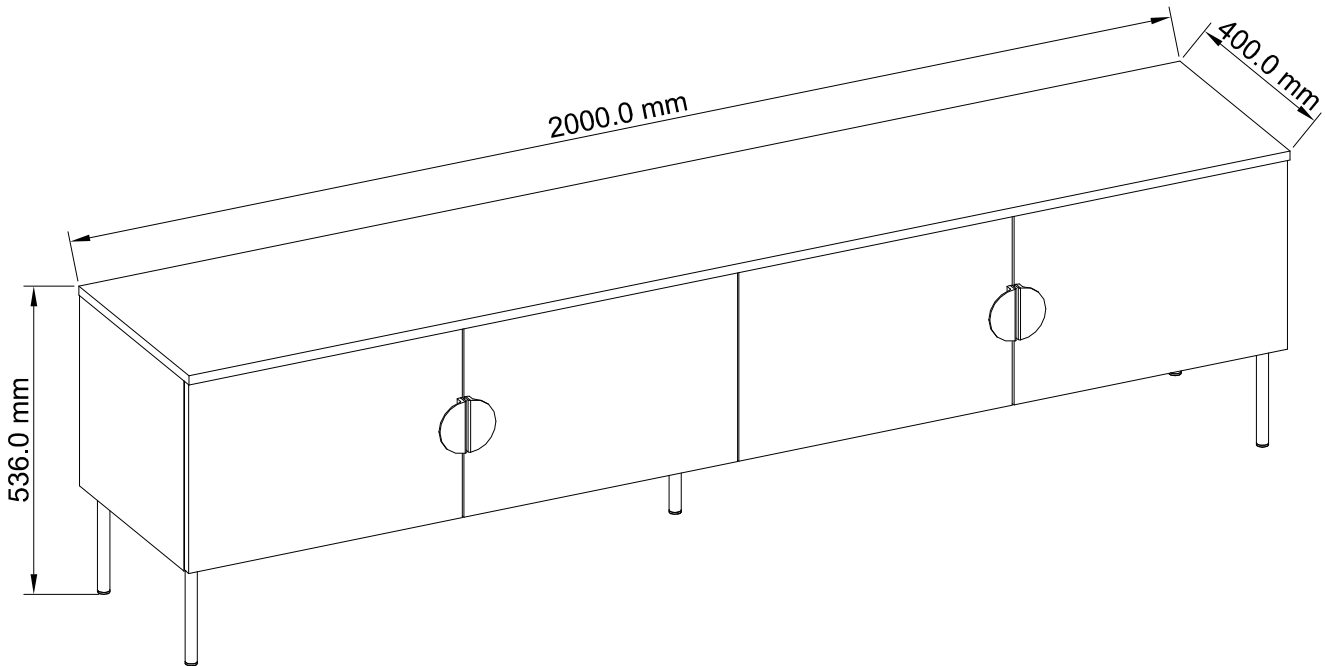

D Montageanleitung
Kommode >Mond<

GB Assembly instructions
Dresser >Mond<

SRB Упутства за инсталацију
ГРУДИ фиоке >Mond<

FR Notice de montage
La commode >Mond<

IT Istruzioni di montaggio
Costumista >Mond<

HR Upute za instalaciju
Komoda >Mond<

NL Handleiding voor de montage
Dressoir >Mond<

PL Instrukcja montażu
Komoda >Mond<

SL Návod na montaž
Komoda >Mond<

CZ Montážní návod
Prádelník >Mond<

SK Návod na montáž
Dresser >Mond<

LT Surinkimo instrukcijos
Komoda >Mond<

HU Szerelési útmutató
Öltözőködöaszta >Mond<

RO Instrucțiuni de montaj
Dulap >Mond<

LV Montāžas instrukcija
Komoda >Mond<

TR Montaj talinatl
Şifonyer >Mond<

RU Инструкция по монтажу
Комод >Mond<

EE Kokkupaneku juhised
Komoda >Mond<

ES Instrucciones de montaje
Aparador >Mond<

PT Instruções de montagem
Cómoda >Mond<

BG Инструкции за сглобяване
Скрин >Mond<

BA Upute za sastavljanje
Komoda >Mond<

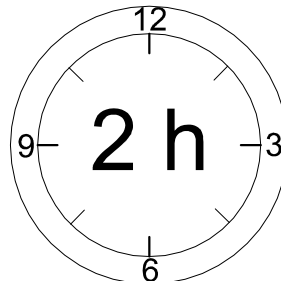
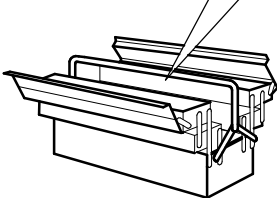
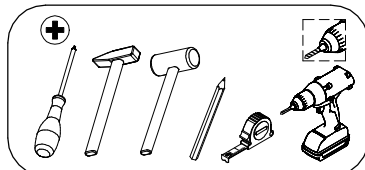
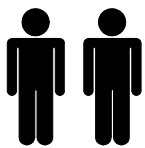

D-Ziehen Sie alle Schrauben sowie tragende Verbindungsteile nach ca. 5 Wochen nach, um einedauerhafte Standsicherheit zu gewährleisten.

GB-After approx. 5 weeks, tighten all screws and load-bearing connecting parts to ensure permanent stability.

FR-Resserrez toutes les vis ainsi que les pièces de fixation au bout d'environ 5 semaines pour garantir une sécurité de fixation durable.

IT- Ristringere tutte le viti e giunture dopo ca. 5 settimane, al fine di garantire una durevole solidità.

NL-Draai alle schroeven en ook dragende verbindingstukken na ca. 5 weken nog eens vast, zodateen continue stabiliteit wordt gegarandeerd.

PL-Prosimy po ok. 5 tygodniach dokręcić wszystkie śruby i elementy łączeniowe. Zagwarantuje to Państwu trwałość i stabilność połączeń.

CZ- Dotáhněte všechny šrouby a nosné spojovací díly přibližně po 5 týdnech, aby se zaručila trvalá stabilita.

SK-Po cca 5 týždňoch dotiahnite skrutky, aby bola zaručená ich trvalá stabilita.

HU-Húzza utána - kb. 5 hét múlva - az összes csavart és a teherhordó összekötő-alkatrészeket abiztonság érdekében.

RO-Pentru a asigura o stabilitate de durată, strângeți după cca. 5 săptămâni toate șuruburile, precumși toate elementele portante de legătură.

TR-Tüm vida ve taşıyıcı bağlantı parçalarını kalıcı bir duruş güvenliğini sağlamak için yaklaşık 5 haftasonra tekrar sıkınız.

RU - Подкрутите все болты, а также несущие соединительные детали приibl. через 5 недель для обеспечения устойчивости в течение длительного времени.

SRB - Molim vas posle akrokca. 5 nedelja zategnite sve šrafove i pričvršćivače. To ће вам гарантовати трајност и стабилност веза.

HR - Molim vas, nakon cca. 5 tjedana zategnite sve vijke i pričvršćivače. To će vam jamčiti trajnost i stabilnost priključaka.

SL - Pýtame sa po cca. 5 týždňov utiahnite všetky skrutky a upevňovacie prvky. To zaručuje trvanlivosť a stabilitu spojov.

LT - Mes prašome po maždaug. 5 savaites priveržkite visus varžtus ir tvirtinimo detales. Taip užtikrinamas jungčių patvarumas ir stabilumas.

LV - Mēs lūdzam pēc apm. 5 nedēļas, pievelciet visas skrūves un stiprinājumus. Tas garantē savienojumu izturību un stabilitāti.

EE - Küsime pärast ca. 5 nädalat, pingutage kõiki kruvisid ja kinnitusi. See tagab ühenduste vastupidavuse ja stabiilsuse.

ES-Apriete todos los tornillos y elementos de conexión después de aproximadamente 5 semanas. Esto le garantizará la durabilidad y estabilidad de sus conexiones.

PT-Por favor, aperte todos os parafusos e elementos de ligação após aproximadamente 5 semanas. Isto garantirá a durabilidade e a estabilidade das suas ligações.

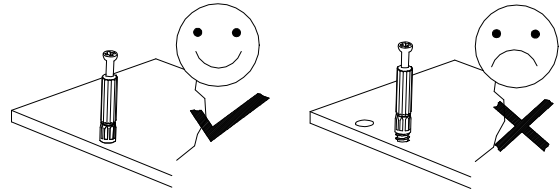

D Bitte nur mit einem Staubtuch oder leicht feuchtem Lappen reinigen. Keine scheuernden Putzmittel verwenden.

GB Please only clean with a duster or a damp cloth. Do not use any abrasive cleaners.

FR Veuillez nettoyer uniquement avec un chiffon à poussière ou un chiffon légèrement humide. Nepas utiliser de détergent abrasif.

IT Si raccomanda di pulire solo con un panno per la polvere o uno strofinaccio umido. Non utilizzaredetergenti abrasivi.

NL Reinig alleen met een stofdoek of een lichtjes vochtige doek. Gebruik geen schurende poetsmid-delen.

PL Czyszczenie należy wykonać wyłącznie za pomocą ściereczki lub lekko nawilżonego ręcznika. Nie stosować środków czyszczących do szorowania.

CZ Čistěte prosím jen prachovkou nebo lehce navlhčeným hadrem. Nepoužívejte drhnuocí čisticíprostředky.

SK Na čistenie používajte len prachovku alebo zľahka navlhčenú utierku. Nepoužívajte žiadnedrhnuce čistiace prostriedky.

HU Kérjük, csak portörló kendővel vagy enyhén nedves ronggyal tisztítsa. Ne használgjon dörzshatású tisztítószert.

RO Vă rugăm să utilizați la curățare exclusiv o cârpă de șters praful sau o cârpă ușor umezită. Nuutilizați substanțe de curățat abrazive.

TR Lütfen sadece bir toz beziyle veya hafif nemli yumuşak bir bezle siliniz. Aşındırıcı temizlik malze-meleri kullanmayınız.

RU Для чистки используйте, пожалуйста, тряпку для пыли или слегка влажную ветошь. Неиспользовать абразивные чистящие средства.

SBR Чишћење треба обавити само крпом или благо влажним пешкиром. Немојте користити средство за чишћење рибања.

HR Čišćenje treba obaviti samo krpom ili blago navlaženim ručnikom. Ne koristite sredstva za čišćenje ribanja.

SL Čistenie by sa malo vykonávať len handričkou alebo ľahko navlhčeným uterákom. Nepoužívajte čistiace prostriedky na drhnutie.

LT Valyti galima tik šluoste arba lengvai sudrėkintu rankšluosčiu. Nenaudokite šveičiamųjų valiklių.

LV Tīršana jāveic tikai ar drānu vai viegli samitrinātu dvieli. Neizmantojiet tīršanas līdzekļus.

EE Puhastada tohib ainult lapiga või kergelt niisutatud rätikuga. Ärge kasutage puhastusvahendeid.

ES La limpieza debe realizarse únicamente con un paño o una toalla ligeramente humedecida. No utilice productos de limpieza abrasivos.

PT A limpeza deve ser feita apenas com um pano ou toalha ligeiramente húmida.

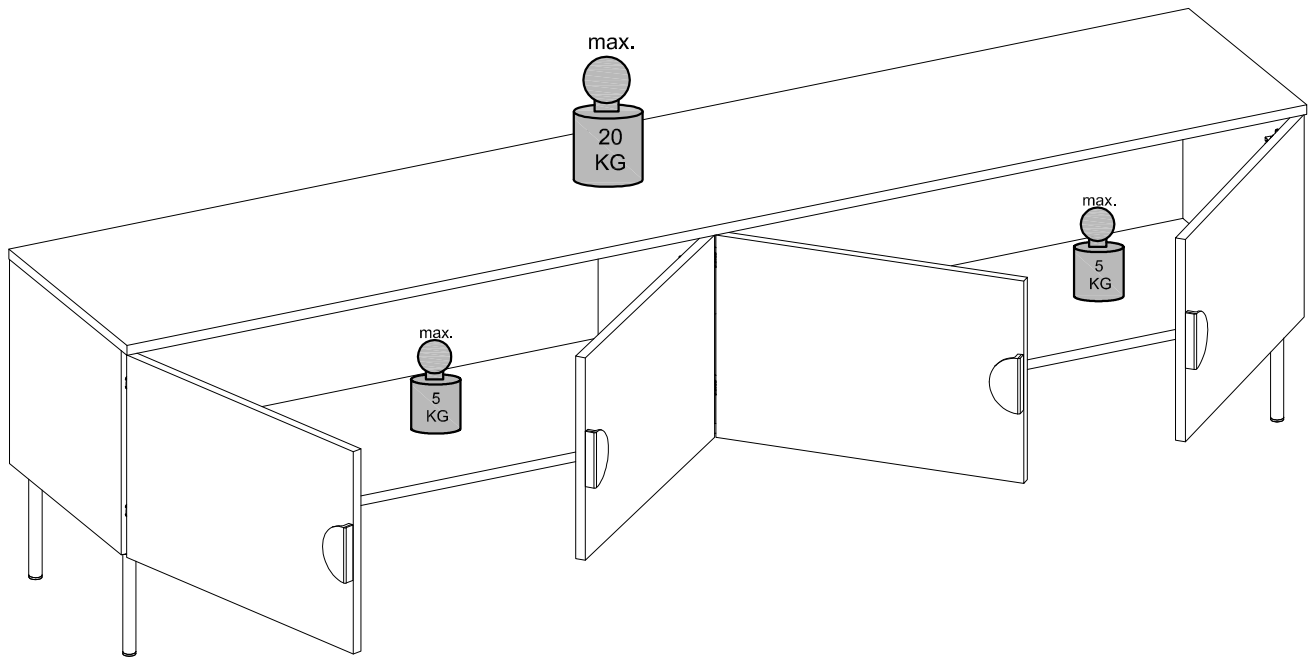
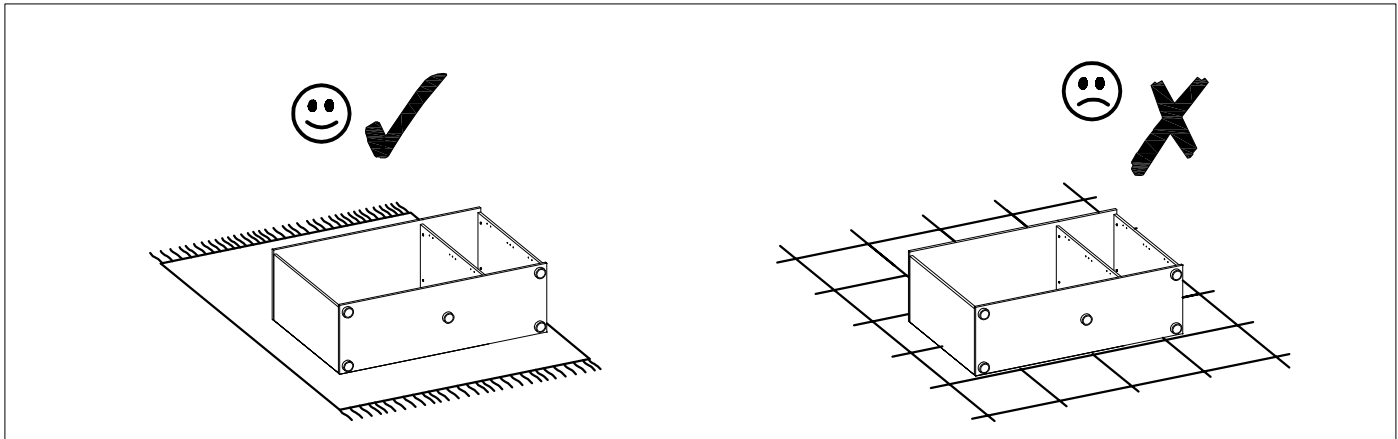
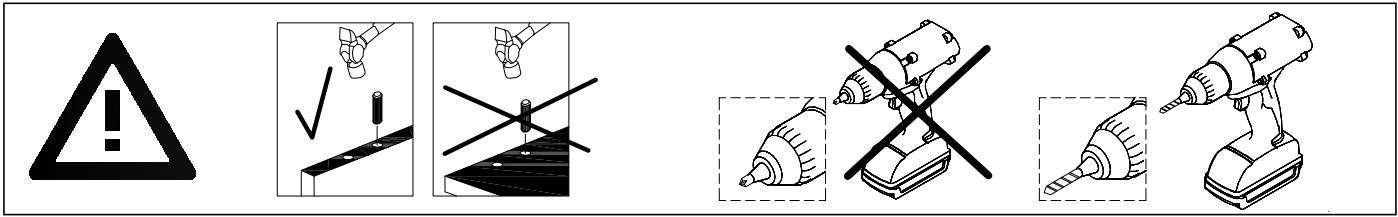
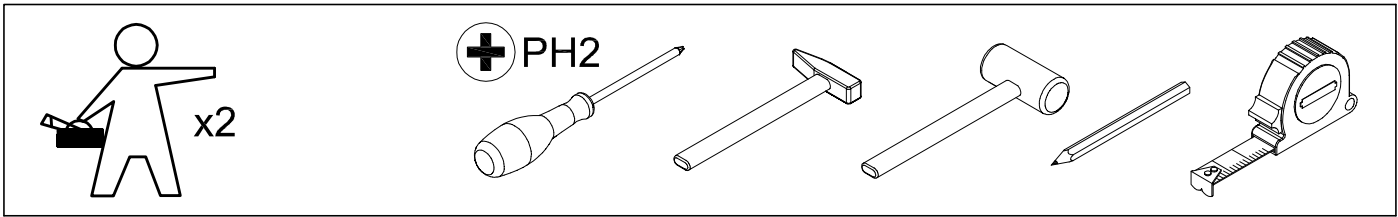

**Service · Assistenza · Dienstverlening · Serwis
Servis · Szerviz · Сервисная служба · Сервис · Serwis · Servis**

Name · Nom · Nome · Naam · Nazwa · Jméno · Název · Név · Denimire · Isim · Название	Mond
Typ · Type · Tip · Típus · Tipo · Тип	09

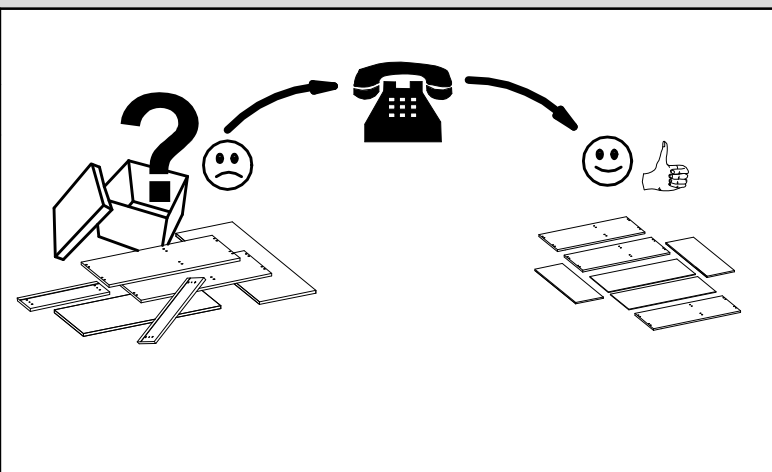
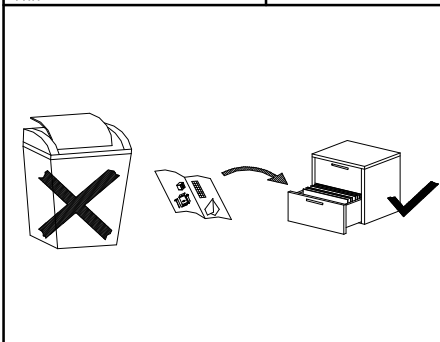

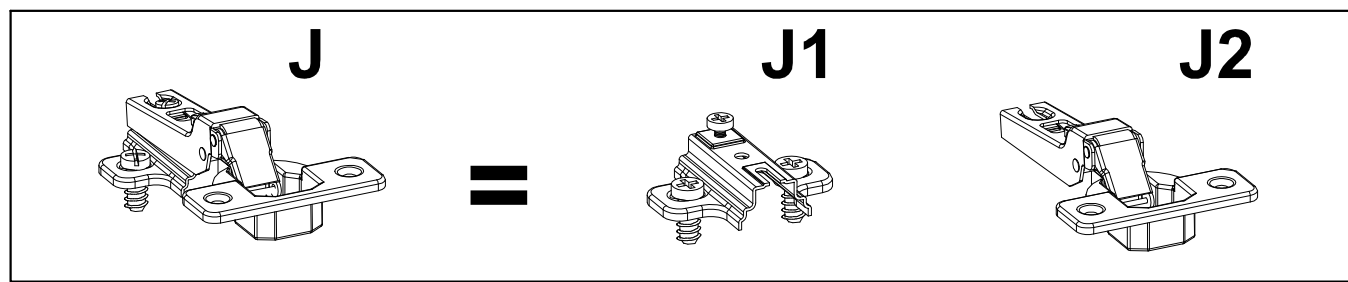
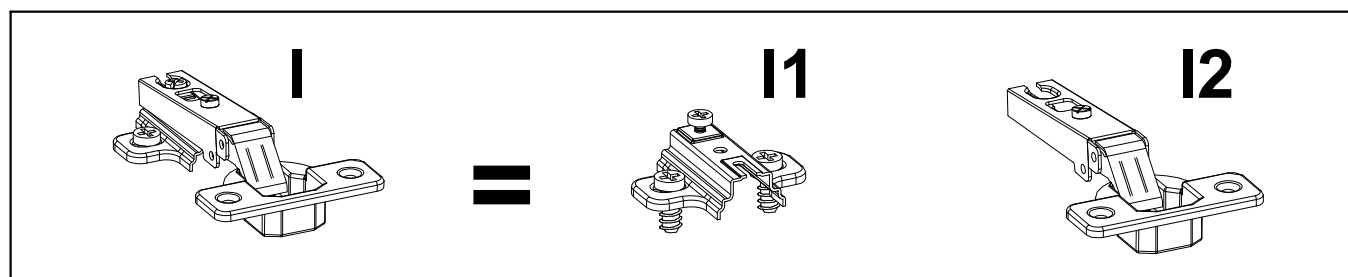

A Ø8x30 mm x12 92597	B Ø6,5x36,5 mm x12 4066	C Ø15x12 mm x12 3996	D Ø20 mm x12 136239	E 15x14x11 mm x10 4044
F Ø3,5x16 mm x36 3918	G Ø60x4 mm x2 4034	H Ø3,0x25 mm x3 3887	I Ø35 mm , KR0 x4 IN01640	J Ø35 mm , KR8 x4 67350
K Ø20, H-180 x5 232943	L 96X48X20 mm x4 236246 236248			

L 96X48X20 mm x4 UMOOG64 236246	L 96X48X20 mm x4 UMOOBL64 236248
---	--

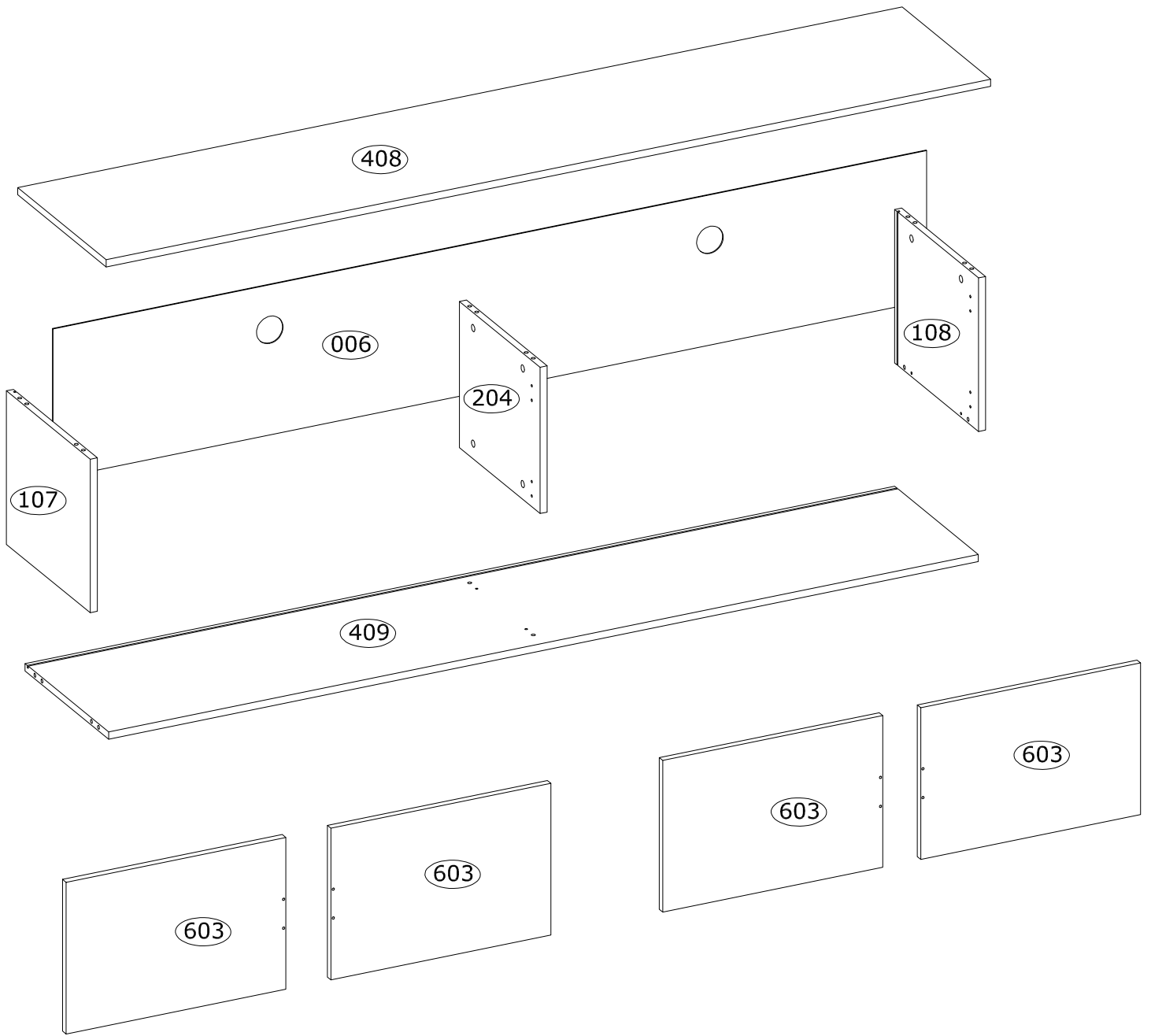



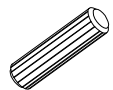

#						
408	2000	400	16	x	1	1/1
409	1966	378	16	x	1	1/1
108	340	379	16	x	1	1/1
107	340	379	16	x	1	1/1
204	324	364	16	x	1	1/1
603	336	497	16	x	4	1/1
006	1975	333	3	x	1	1/1

1

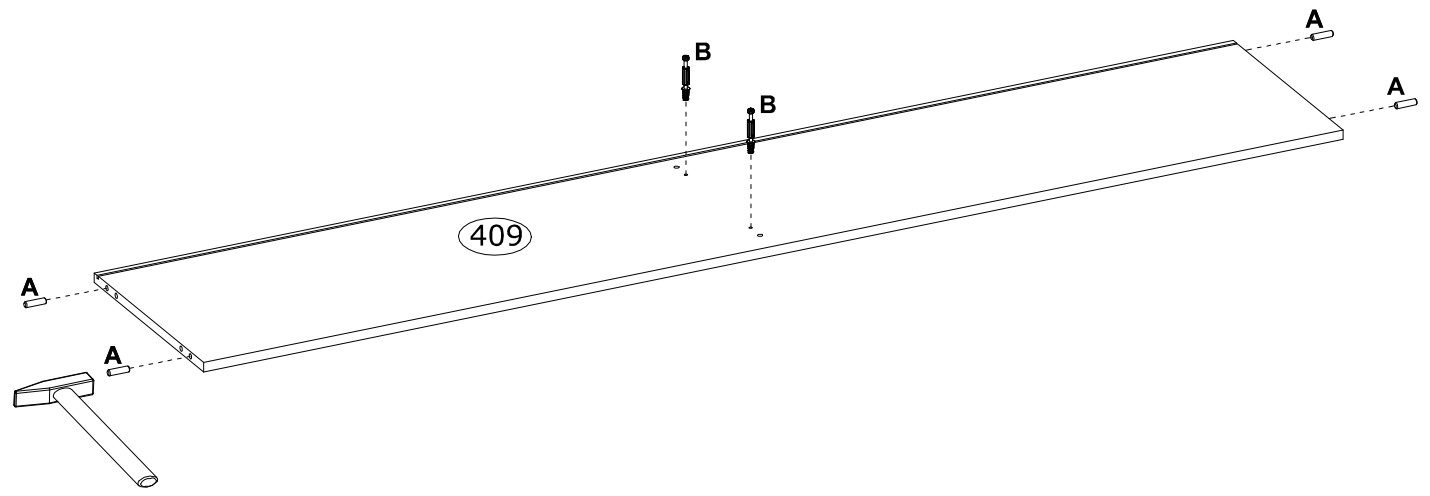
A $\varnothing 8 \times 30$ mm  x4 92597	B $\varnothing 6,5 \times 36,5$ mm  x2 4066	
--	---	--

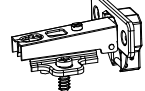

2

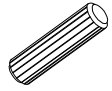
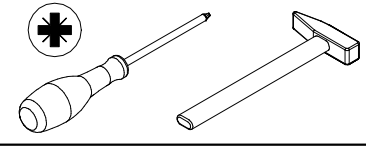
I1 $\varnothing 35$ mm , KR0  x2 IN01640	B $\varnothing 6,5 \times 36,5$ mm  x2 4066	A $\varnothing 8 \times 30$ mm  x2 92597	
---	--	---	---

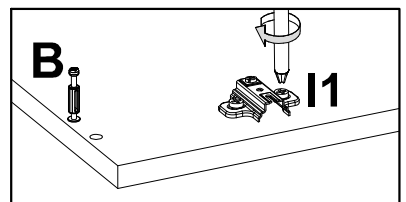
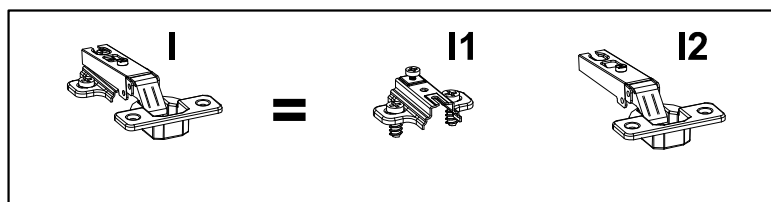
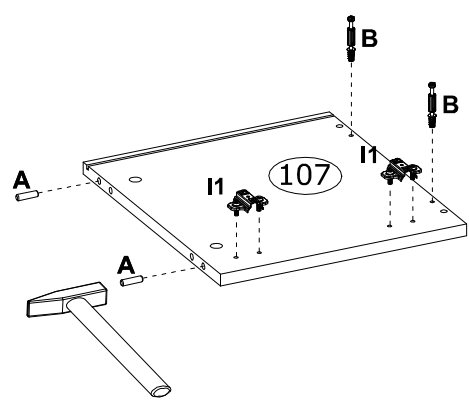

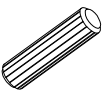
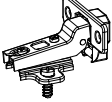
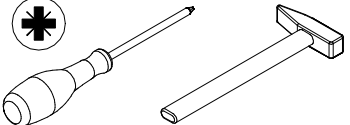

3

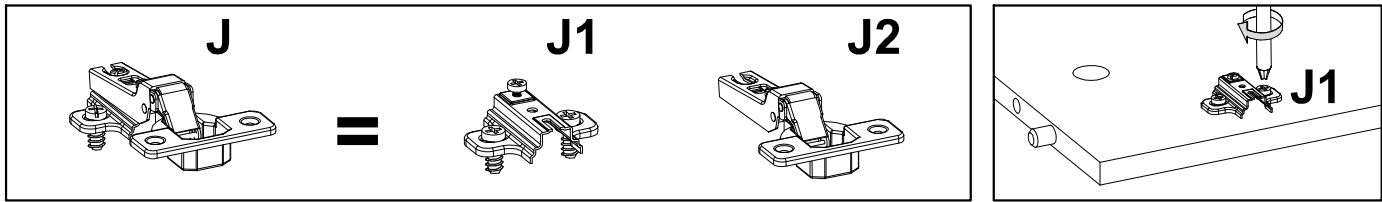
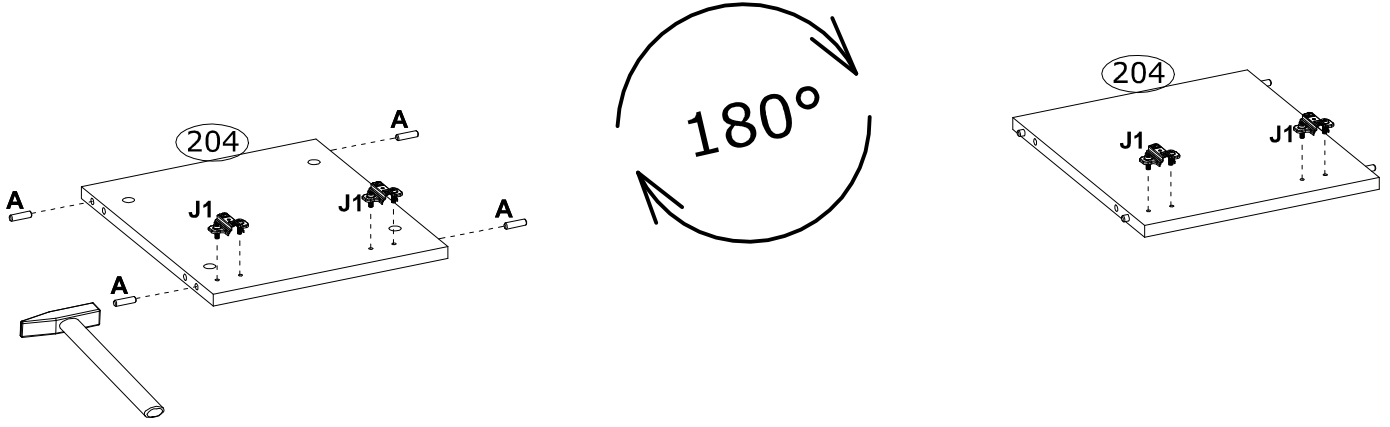
<p>A Ø8x30 mm</p>  <p>x4 92597</p>	<p>J1 Ø35 mm , KR8</p>  <p>x4 67350</p>	
---	--	--

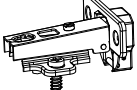

4

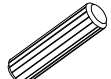
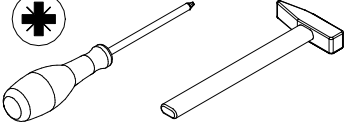
<p>I1 Ø35 mm , KR0</p>  <p>x2 IN01640</p>	<p>B Ø6,5x36,5 mm</p>  <p>x2 4066</p>	<p>A Ø8x30 mm</p>  <p>x2 92597</p>	
---	---	--	---

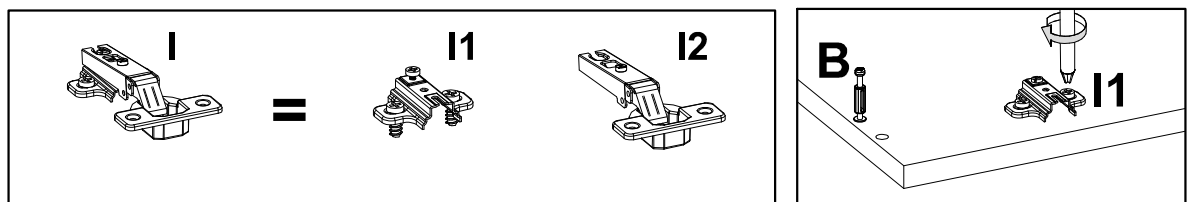
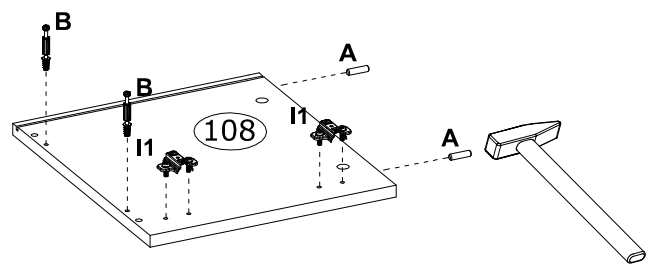

5

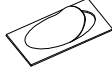
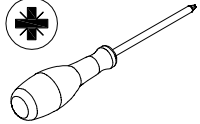
C Ø15x12 mm  x2 3996	D Ø20 mm  x2 136239	
--	---	--

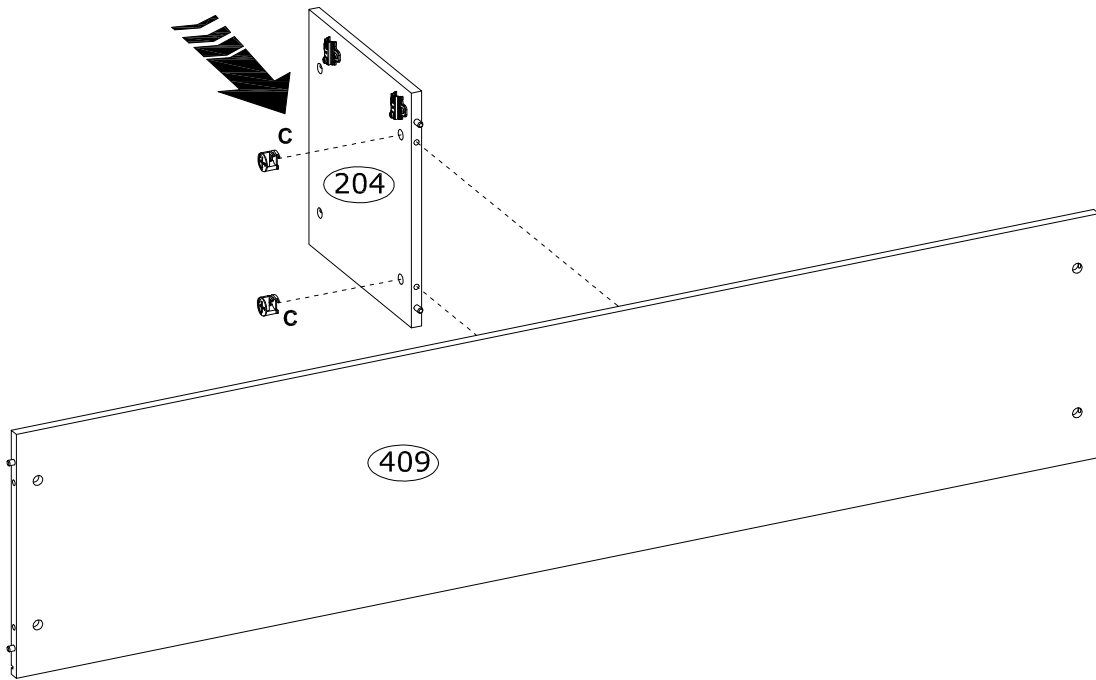

6

C Ø15x12 mm  x4 3996	D Ø20 mm  x4 136239	
--	---	---

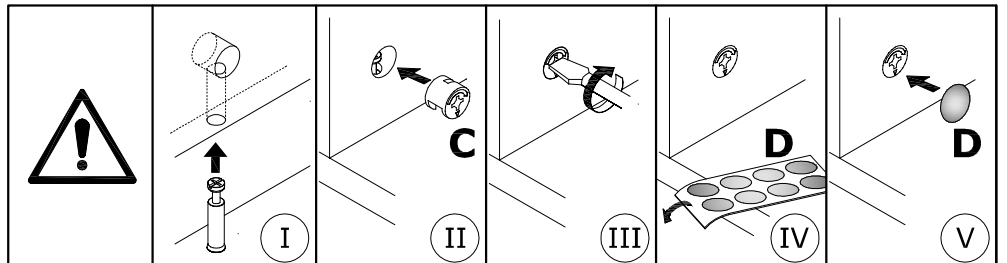
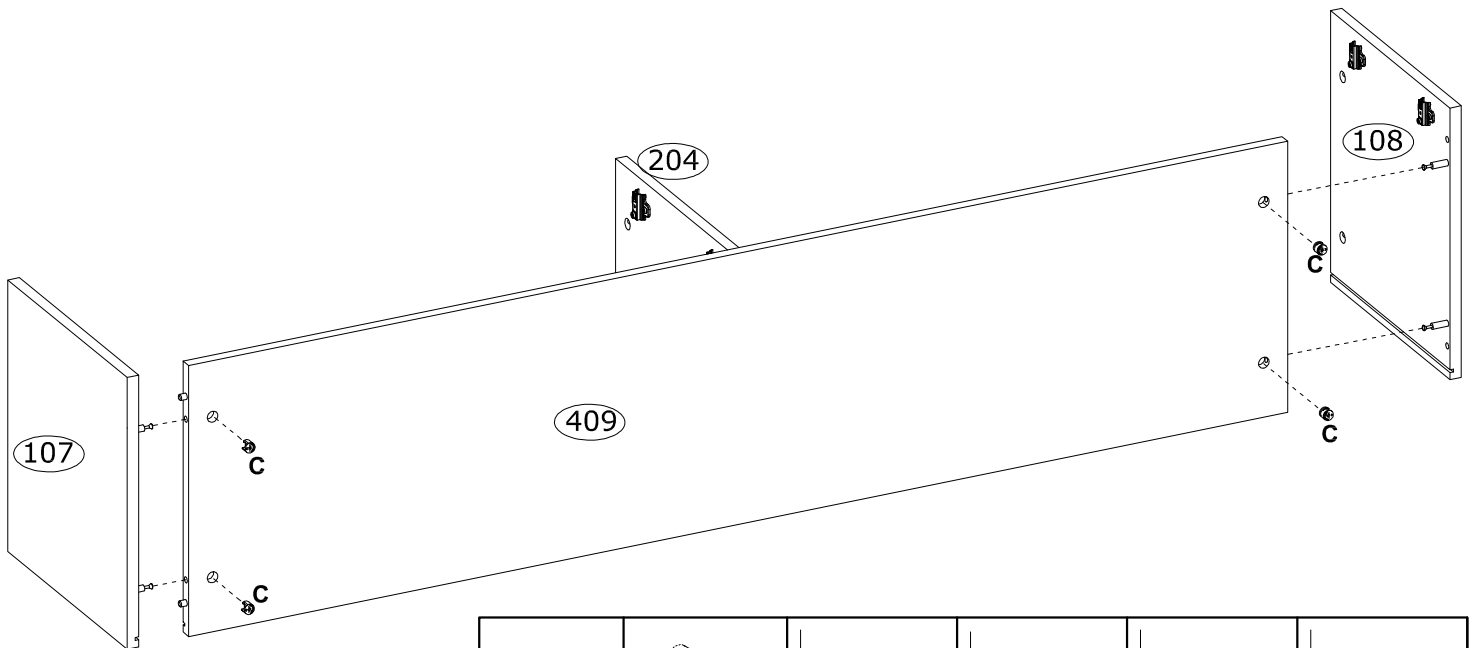

7

K Ø20, H-180 x5 232943	F Ø3,5x16 mm x20 3918	
--	---------------------------------------	--

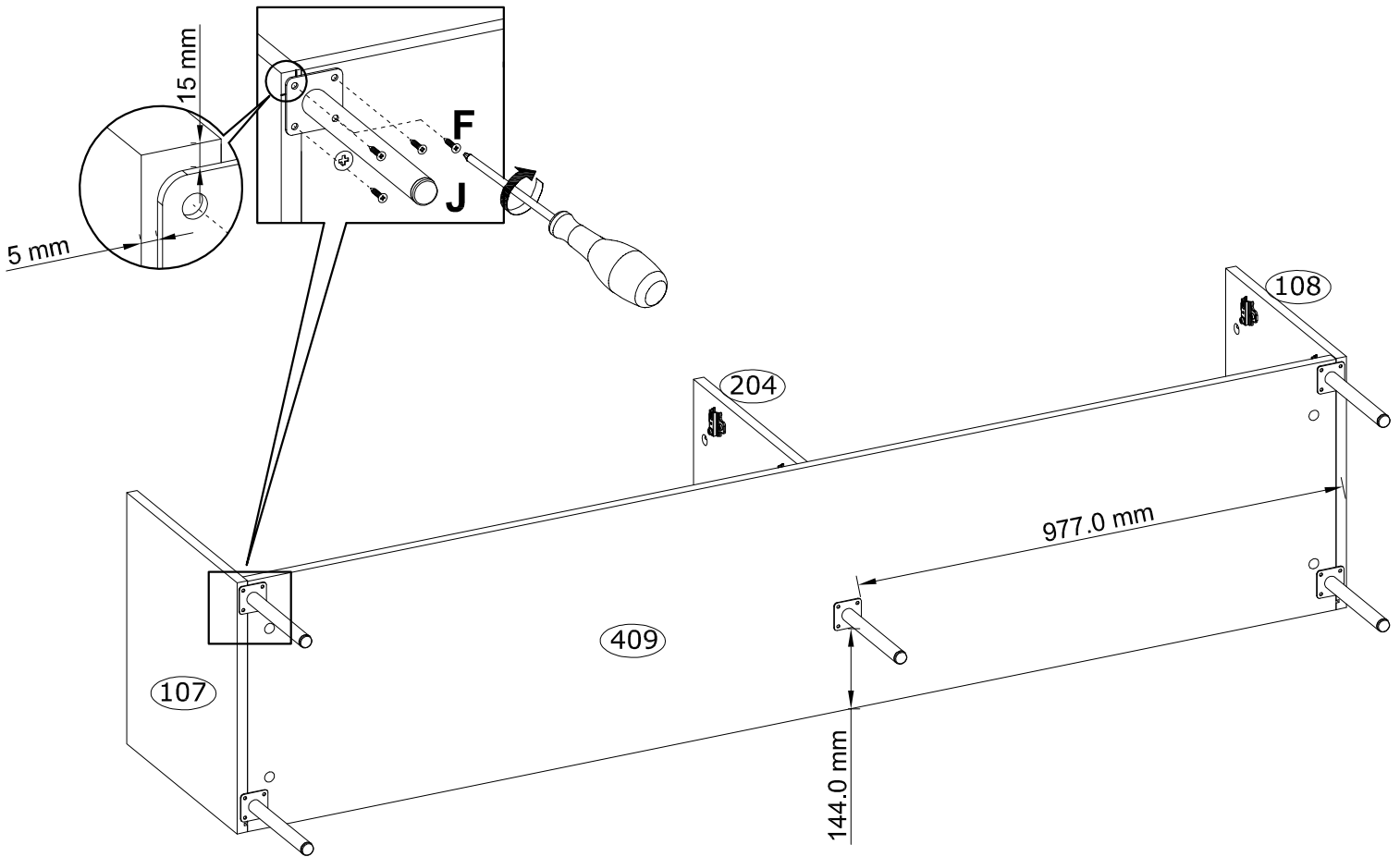
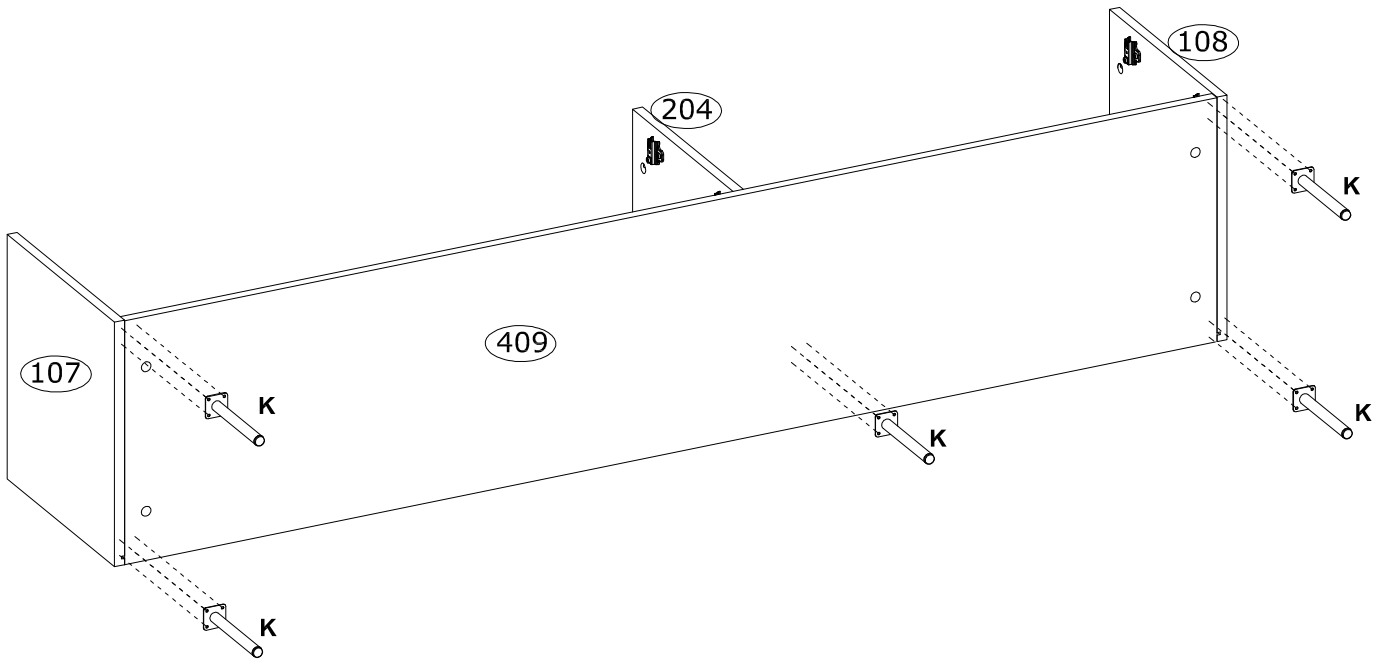

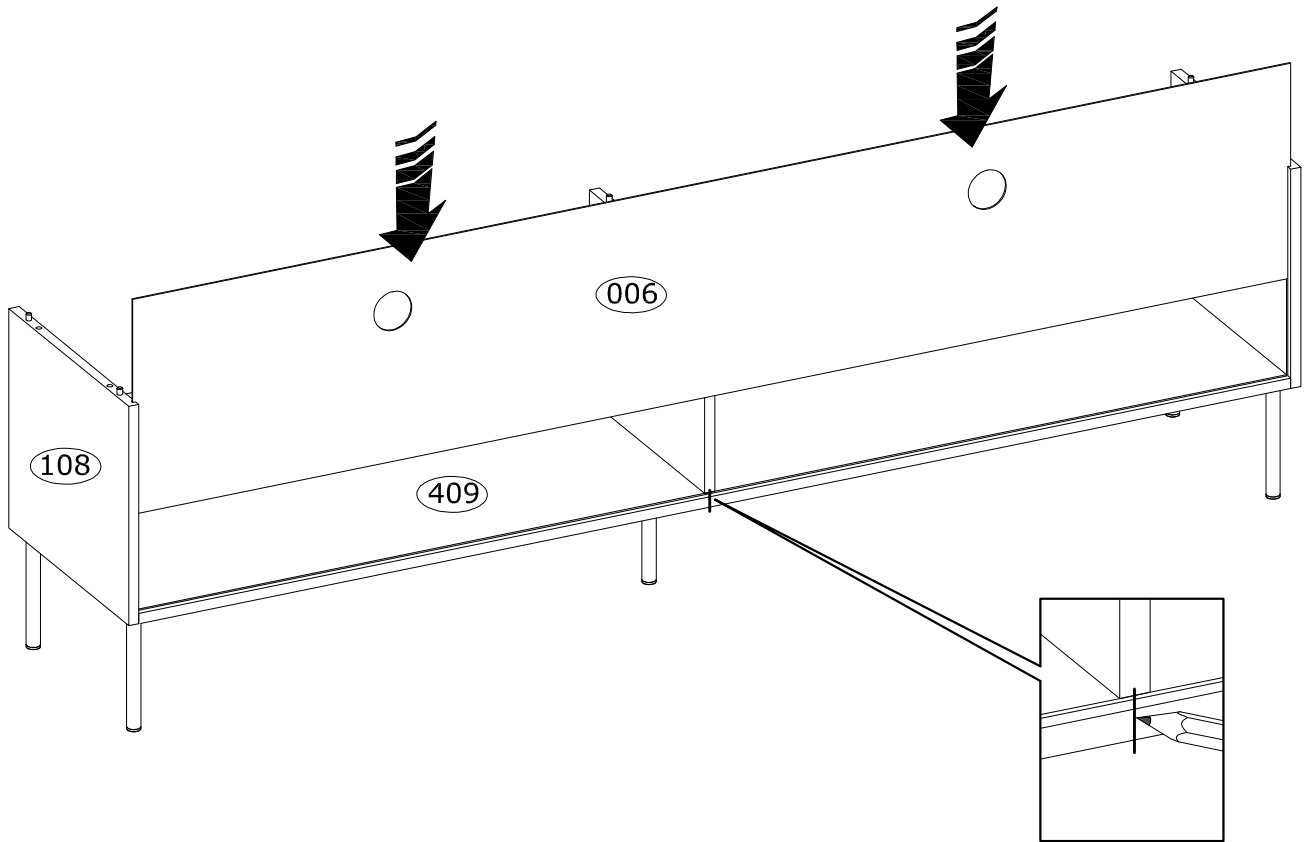

8

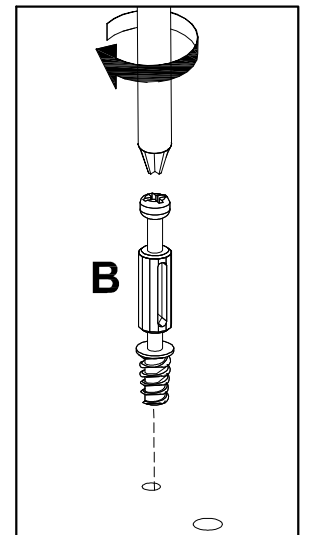
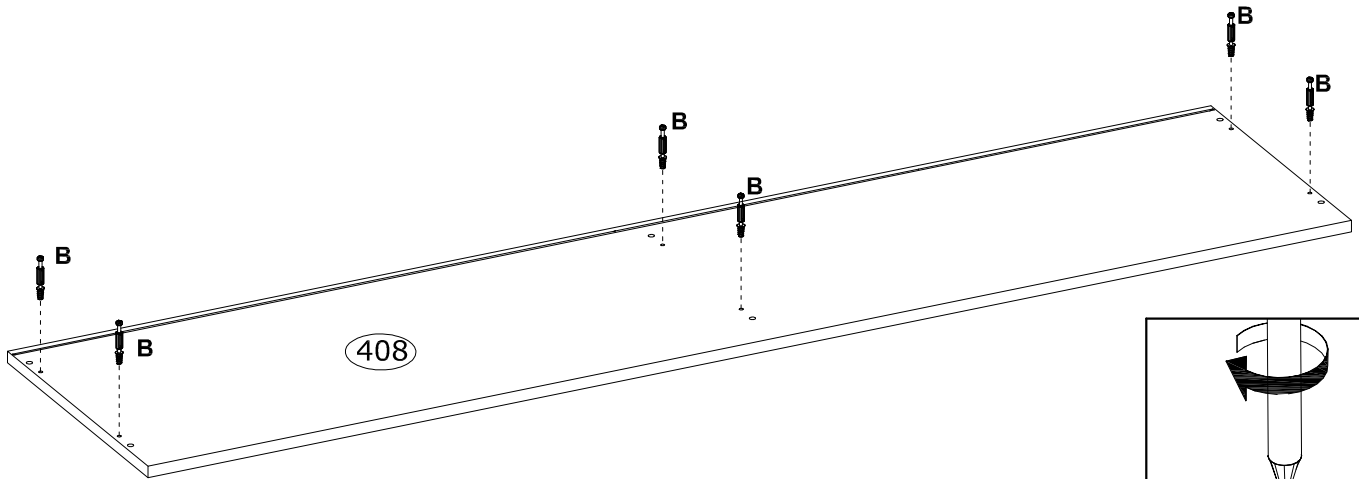
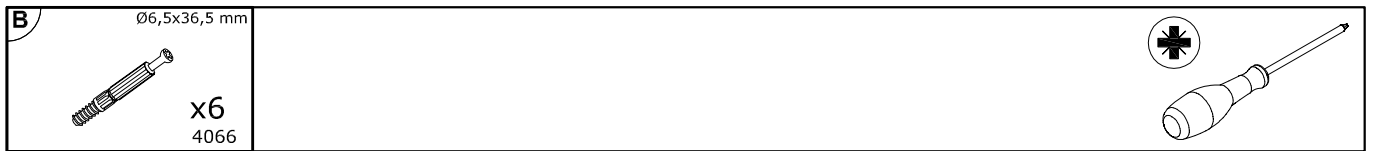

9



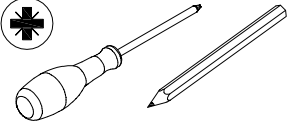

10

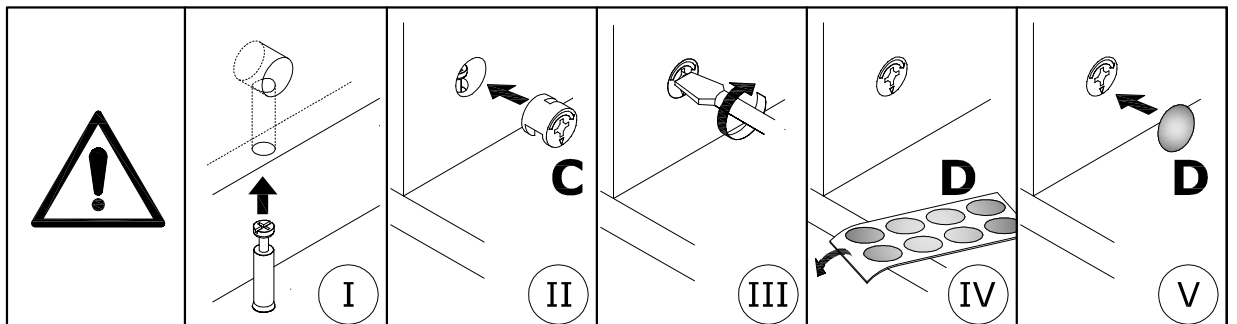
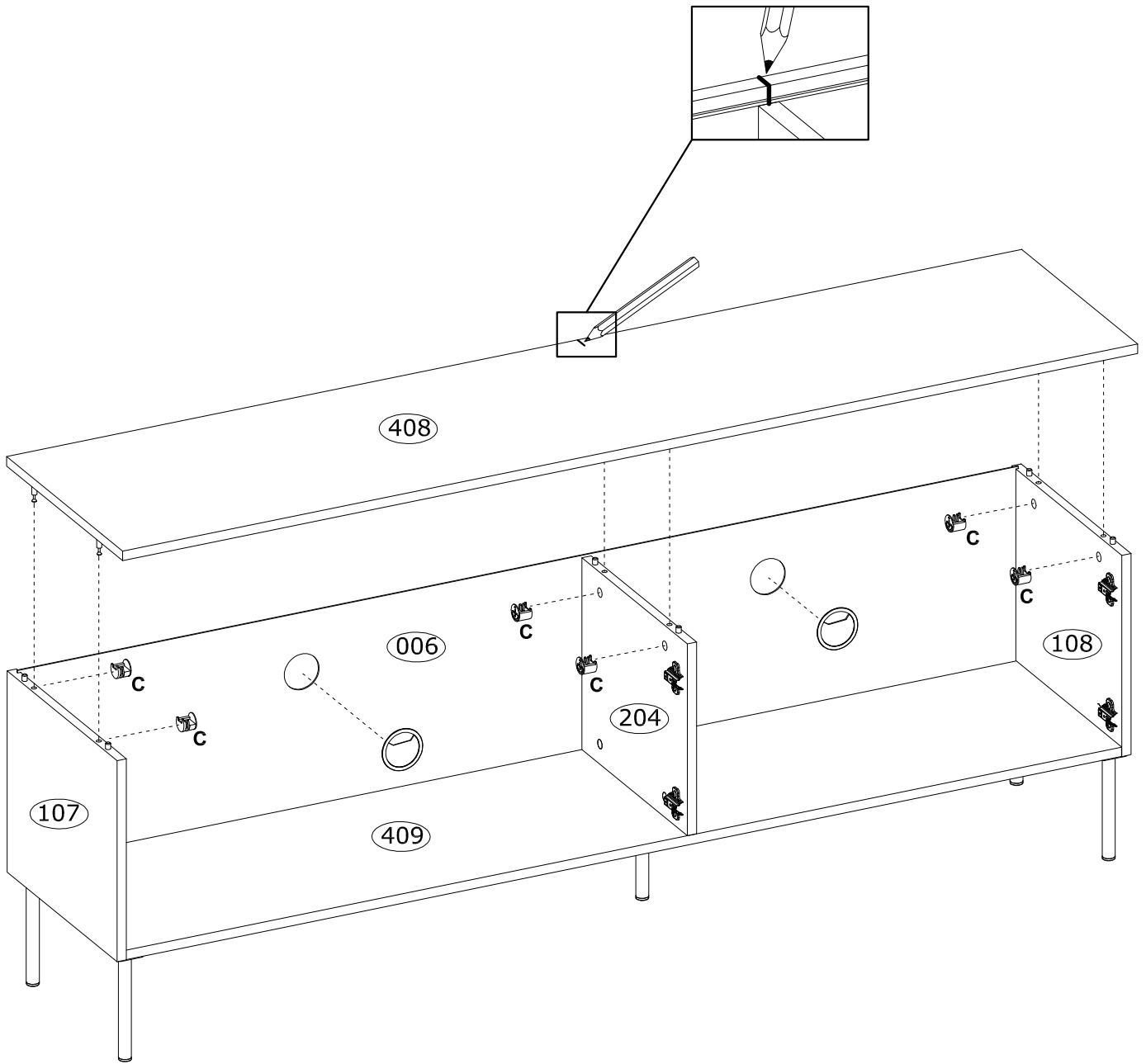
G Ø60x4 mm  x2 4034	C Ø15x12 mm  x6 3996	D Ø20 mm  x6 136239	
---	--	---	--



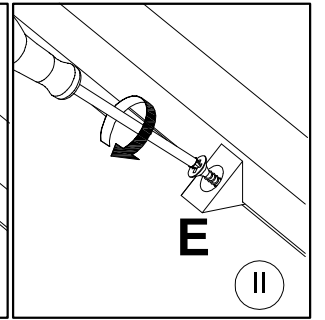
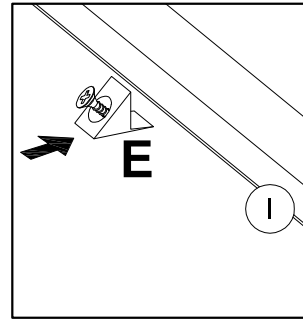
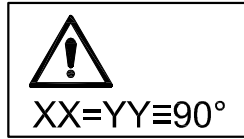
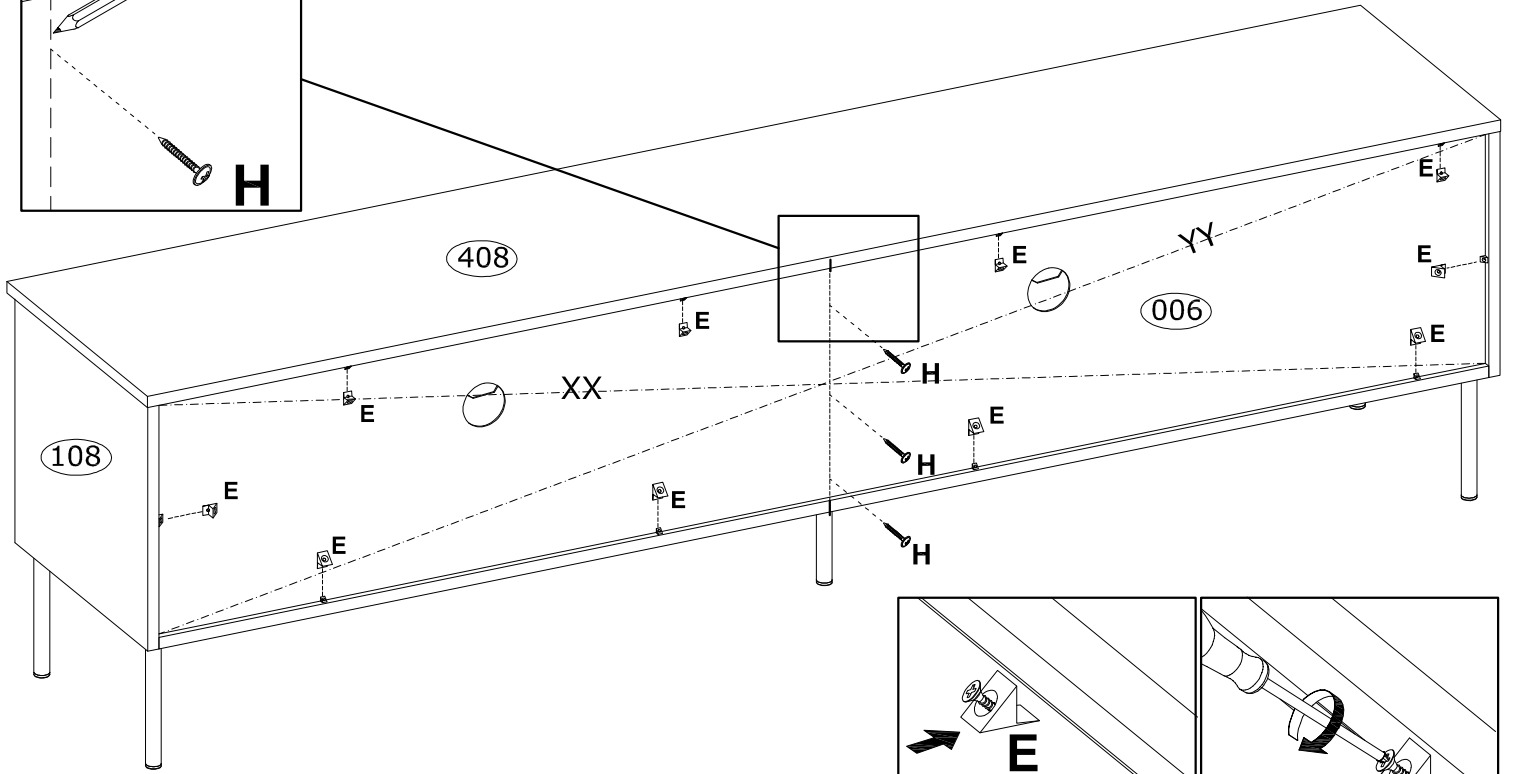
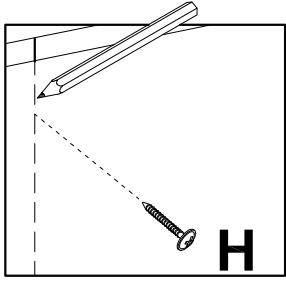
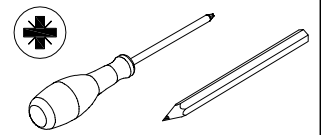

11

H Ø3,0x25 mm  x3 3887	E 15x14x11 mm  x10 4044
---	---

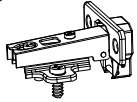

12

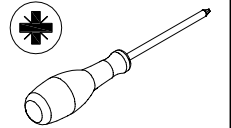

I Ø35 mm , KR0  x4 IN01640	F Ø3,5x16 mm  x8 3918	L 96X48X20 mm  x2 236246 236248
--	---	---

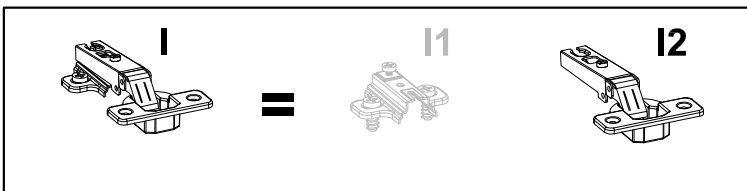
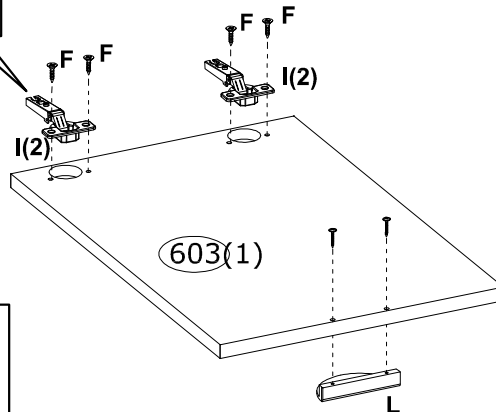
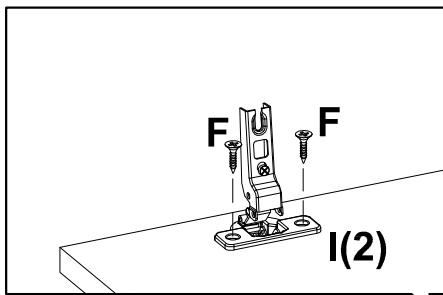

x2

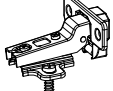

13

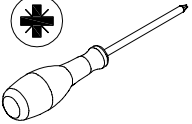
J Ø35 mm , KR8  x4 67350	F Ø3,5x16 mm  x8 3918	L 96x48x20 mm  x2 236246 236248	
--	---	---	--

x2

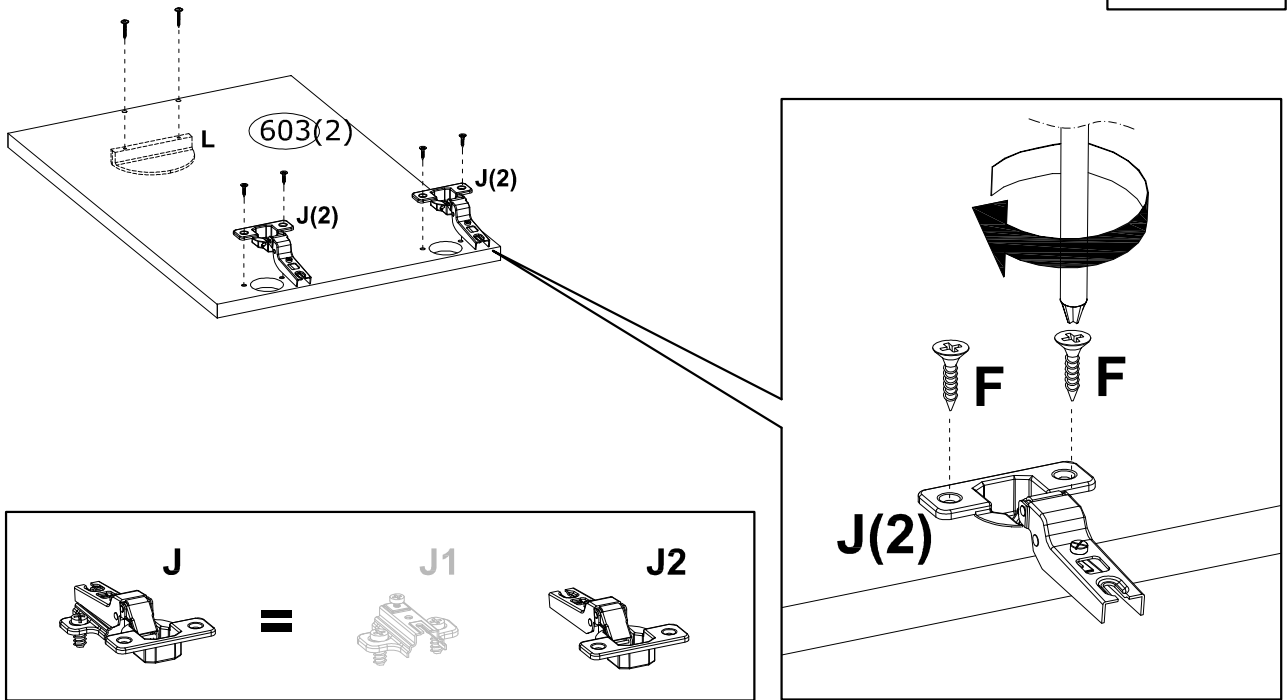

14

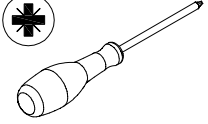

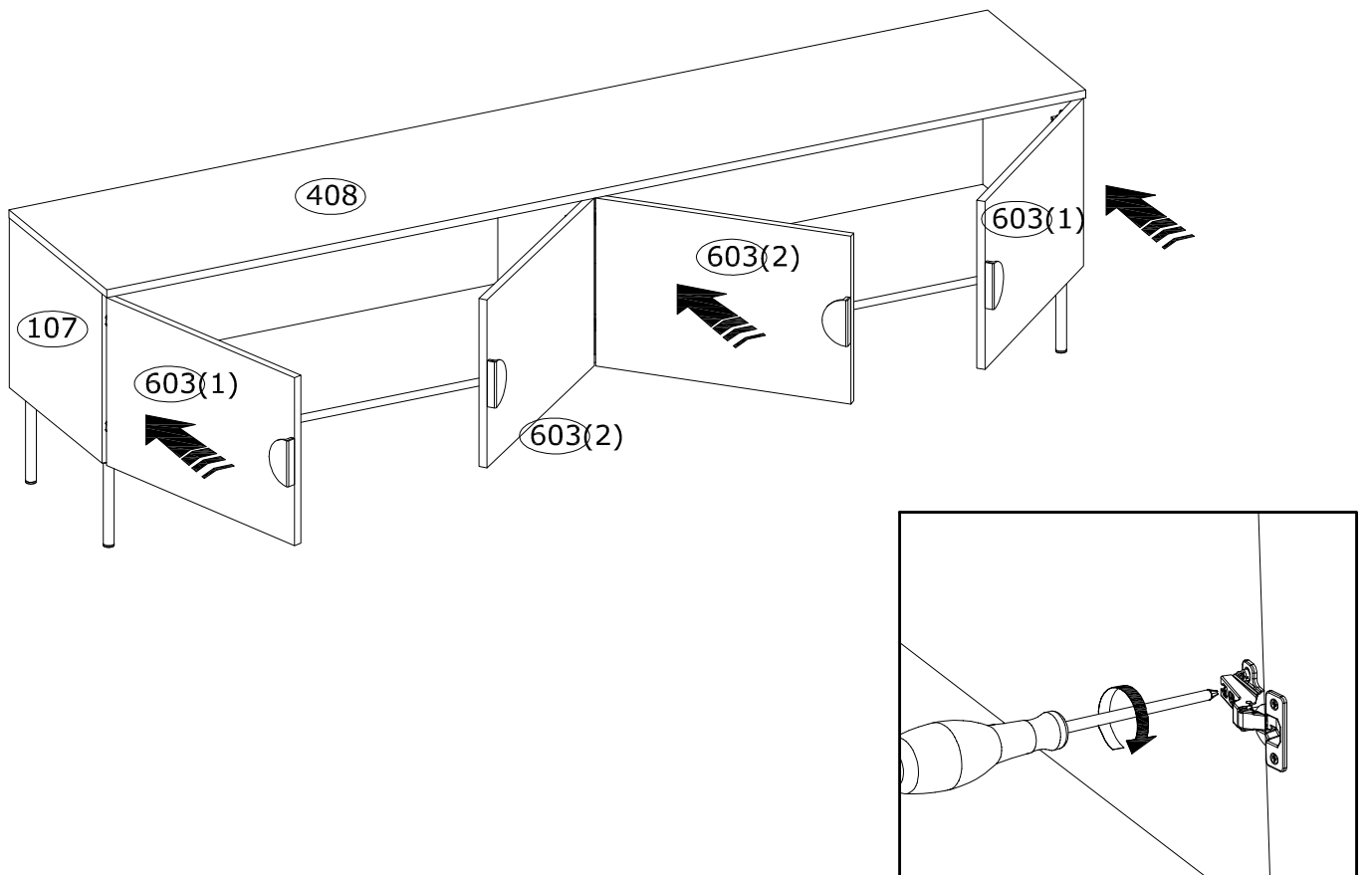

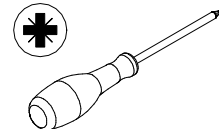

Türen einstellen (Scharniere justieren)
Adjusting the door (adjusting the hinges)
Régler les portes (ajuster les charnières)
Sistemare le porte (regolare le cerniere)
Deuren instellen (scharnieren afstellen)
Nastawić drzwi (wyregulować zawiasy)
Vyrovňajte dviřka (seřid'te závěsy)
Nastavenie dverí (nastavenie závesov)
Állítsa be az ajtókat (állítsa be a zsanérokát)
Ajustar la puerta (ajustar las bisagras)
Podesite vrata (podesite šarke)

Reglare uși (ajustare balamale)
Kapilarin ayarlanması (menteşelerin seviye ayarı)
Регулировка дверей (регулировка шарнира)
Поставите врата (подесите шарке)
Postavite vrata (podesite šarke)
Nastavenie dverí (nastavenie závesov)
Sureguliuokite duris (sureguliuokite vyrius)
Pielāgojiet durvis (noregulējiet eņģes)
Reguleeri uks (reguleeri hinged)
Ajuste a porta (ajuste as dobradiças)
Регулиране на вратата (регулиране на пантите)

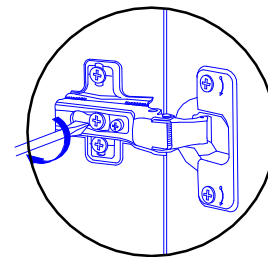
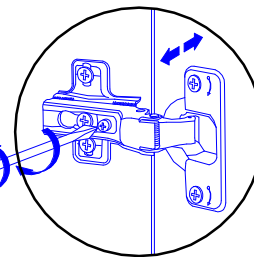
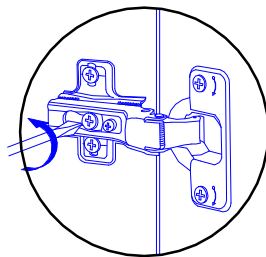
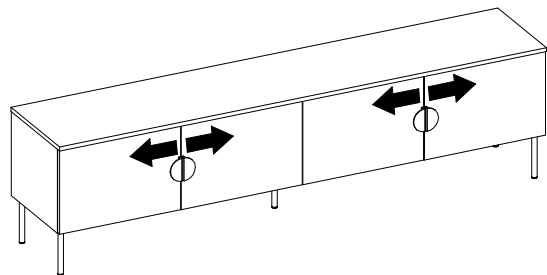
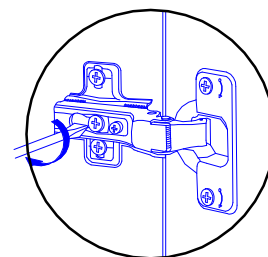
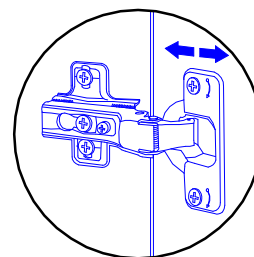
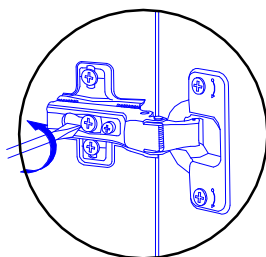
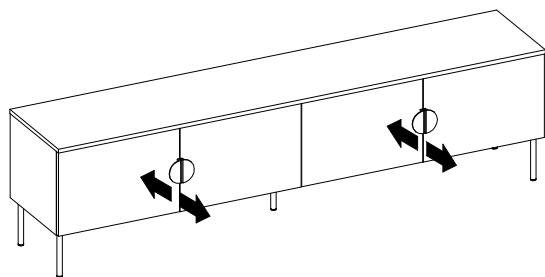
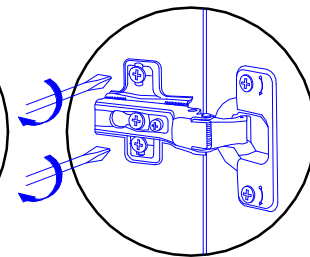
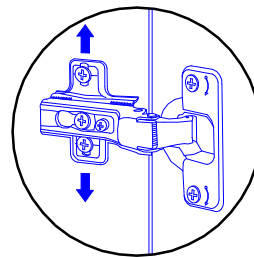
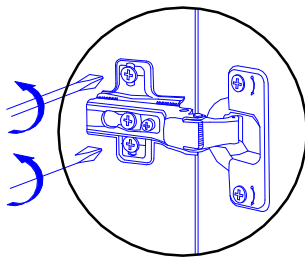
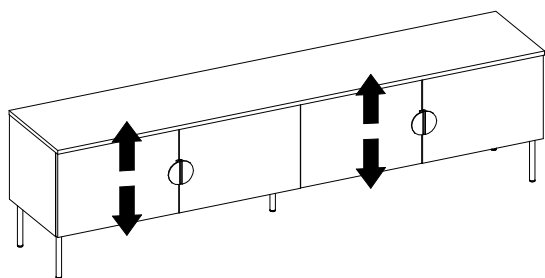

- D** Sicherheits- und Pflegehinweise
- FR** Conseils de sécurité et d'entretien
- NL** Veiligheids- en onderhoudstips
- CZ** Tipy pro bezpečnost a údržbu
- HU** Biztonsági és karbantartási tanácsok
- TR** Güvenlik ve bakım ipuçları
- ES** Instruções de segurança e manutenção
- SRB** Савети за безбедност и одржавање
- SL** Nasveti za varnost in vzdrževanje
- LV** Drošības un apkopes padomi

- GB** Safety and maintenance tips
- IT** Consigli per la sicurezza e la manutenzione
- PL** Wskazówki dotyczące bezpieczeństwa i konserwacji
- SK** Tipy na bezpečnosť a údržbu
- RO** Sfaturi de siguranță și întreținere
- RU** Советы по безопасности и обслуживанию
- PT** Instruções de segurança e manutenção
- HR** Savjeti za sigurnost i održavanje
- LT** Saugos ir priežiūros patarimai
- EE** Ohutus- ja hooldusnõuanded

