

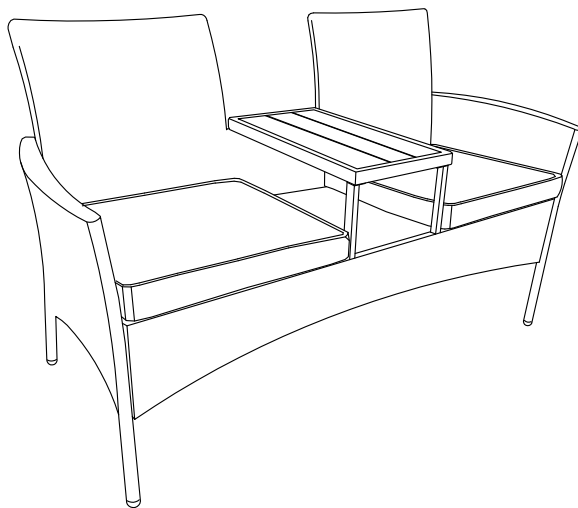











ASSEMBLY INSTRUCTIONS

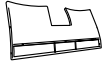

THANK YOU FOR PURCHASING

Installation of products:

	PARTLIST	DESCRIPTION	QTY		HARDWARE	DESCRIPTION	QTY
A		Right handrail	1	a		WASHERs M6	18
B		Left handrail	1	b		Bolts M6*15	2
C		Double-seater board	1	c		Bolts M6*35	12
D		Front section	1	d		Bolts M6*40	4
E		Backrest	1	Y		HEX WRENCH	1
F		Table top	1				
G		Seat cushions	2				

Step1.

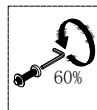
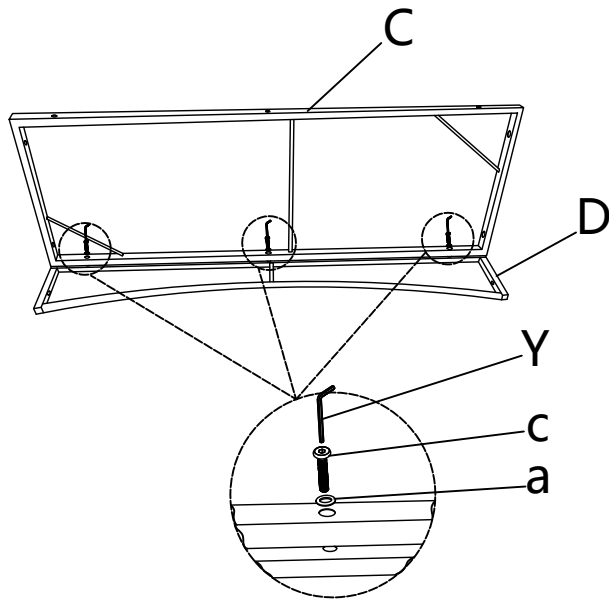

Step2.

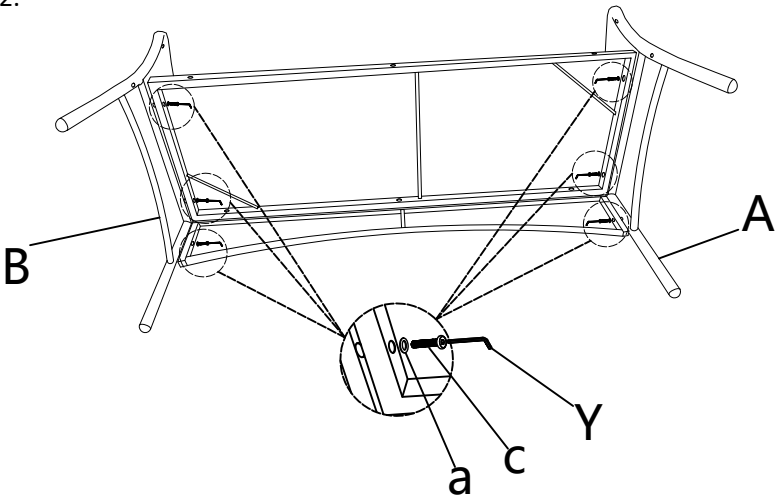

Step3.

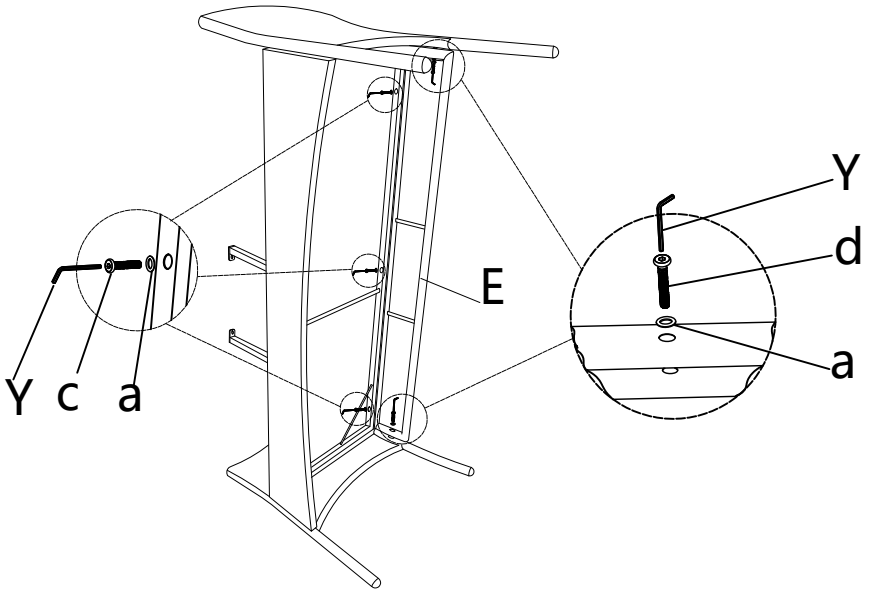

Step4.

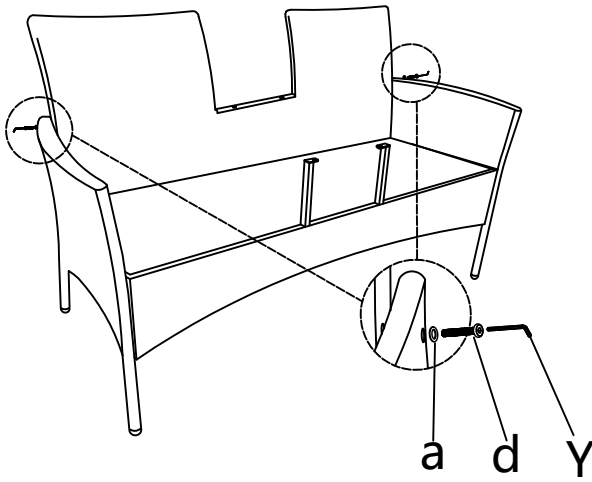

Step5.

